

Jøtul GF 370 DV II IPI Direct Vent Gas Stove

Pilot on Demand Ignition

Installation and Operation Instructions

*Certified to ANSI Z21.88-2019 • CSA 2.33-2019 and
CAN/CGA 2.17-M-17.*

INSTALLER: Leave this manual with the appliance.
CONSUMER: Retain this manual for future reference.

WARNING: If the information in these instructions is not followed exactly, a fire or explosion may result causing property damage, personal injury or loss of life.

- Do not store or use gasoline or other flammable vapors and liquids in the vicinity of this or any other appliance.
- **WHAT TO DO IF YOU SMELL GAS**
 - Do not try to light any appliance.
 - Do not touch any electrical switch; do not use any phone in your building.
 - Immediately call your gas supplier from a neighbor's phone. Follow the gas supplier's instructions.
 - If you cannot reach your gas supplier, call the fire department.
- Installation and service must be performed by a qualified installer, service agency or the gas supplier.
- In the Commonwealth of Massachusetts, a carbon monoxide (CO) detector shall be installed in the same room as the appliance.

This appliance may be installed in an aftermarket, permanently located, manufactured home or mobile home, where not prohibited by local codes.

This appliance is only for use with the types of gas indicated on the rating plate. A conversion kit is supplied with the appliance.

⚠ DANGER



**HOT GLASS WILL
CAUSE BURNS.**

**DO NOT TOUCH GLASS
UNTIL COOLED.**

**NEVER ALLOW CHILDREN
TO TOUCH GLASS.**

A barrier designed to reduce the burn hazard from the glass viewing area is provided with this appliance and shall be installed for the protection of children and other at-risk individuals.

THIS OWNER'S MANUAL PROVIDES INFORMATION TO ENSURE SAFE INSTALLATION AND EFFICIENT, DEPENDABLE OPERATION OF YOUR FIREPLACE INSERT. PLEASE READ THESE INSTRUCTIONS IN THEIR ENTIRETY AND MAKE THEM AVAILABLE TO ANYONE USING OR SERVICING THIS GAS INSERT.

DO NOT ATTEMPT TO ALTER OR MODIFY THE CONSTRUCTION OF THIS APPLIANCE OR ITS COMPONENTS. ANY MODIFICATION OR ALTERATION WILL VOID THE WARRANTY, CERTIFICATION AND LISTING OF THIS APPLIANCE.

THIS HEATER MUST BE INSTALLED AND MAINTAINED BY A QUALIFIED SERVICE AGENCY.

Suggested Tools for Installation and Service

- External regulator (for Propane only)
- Piping which complies with local code
- Manual shut-off valve - T-Handle required in Massachusetts
- Sediment trap - if required by code
- Tee joint
- Pipe wrench
- Pipe sealant
- 10 mm open end wrench
- 1/2", 7/16" open end wrench
- Phillips head screwdriver
- Flat head screwdriver
- 1/4" nut driver
- Work Gloves
- Safety glasses
- Torx T-20 screwdriver
- Tin snips

PLEASE NOTE:

Initial Break-in

It is normal for smoke and odor to occur during the initial stages of operation, depending upon temperatures generated over time. This "curing" condition can be alleviated by promoting fresh air circulation within the immediate vicinity of the appliance. See page 28 for further information.

Operation Sound

Please be aware that cast iron and steel components expand and contract with temperature fluctuations that are often accompanied by "creaking" or "pinging" sounds. This is the result of natural thermal activity.

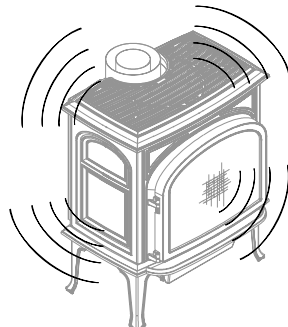

The blower fan will also generate a slight hum at the low setting and progressively increase with the velocity of forced air.

Installation Requirements for the Commonwealth of Massachusetts

THIS PRODUCT MUST BE INSTALLED BY A LICENSED MASTER OR JOURNEYMAN PLUMBER OR GAS-FITTER WHEN INSTALLED IN THE COMMONWEALTH OF MASSACHUSETTS.

1. If there is not one already present, on each floor level where there are bedroom(s), a carbon monoxide detector and alarm shall be placed in the living area outside the bedroom(s). The carbon monoxide detector shall comply with NFPA 720 (2005 Edition).
2. A carbon monoxide detector shall:
 - a) Be located in the room that houses the appliance or equipment;
 - b) Be either hard-wired or battery powered or both; and
 - c) Shall comply with NFPA 720 (2002 Edition).
3. A Product-approved vent terminal must be used, and if applicable, a Product-approved air intake must be used. Installation shall be in strict compliance with the manufacturer's instructions. A copy of the installation instructions must remain with the appliance or equipment at the completion of the installation.



We recommend that our gas products be installed and serviced by professionals who are certified in the U.S. by the National Fireplace Institute® (NFI) as NFI Gas Specialists.

Canada		
ENERGUIDE		
Gas Fireplace Energy Efficiency Rating		
Natural Gas	/ 71.14%	
Propane	/ 64.13%	
Based on CSA P.4.1-15		
Model No.	Jøtul GF 370 DV II IPI	

Table of Contents

Installation & Service Tools	2
Specifications	4
General Information.....	5
Safety Information	6
Installation	
Hearth Requirements	7
Clearances.....	7
Vent Requirements	
Approved Vent Manufacturers.....	8
Vertical Termination	8
Masonry Chimney Conversion	9
Horizontal Termination	10
Vent Termination Clearances	11
Vent Restriction Adjustments.....	12
Vent Termination Diagram	13
Stove Assembly	
1. Glass Frame Removal	14
2. Routing the Power Supply	14
3. Gas Connection	14
4. Gas Pressure	15
5. Fuel Conversion.....	16
6. High Altitude Adjustment.....	18
7. Skamol Panel Installation	18
8. Reflective Panel Installation.....	18
9. River Rock Installation.....	19
10. StarFire Glass Installation	19
11. Log Set Installation.....	20
12. Outer Decorative Glass Panels ...	21
13. System Check	22
14. Flame Picture Adjustment.....	23
Operation	
System Overview	24
Control Functions	25
Maintenance	
Annual Cleaning.....	27
Glass Replacement	27
Battery Replacement	28
Accent Lamp Replacement	28
Wiring Diagram	29
Appendix	
Top Plate Shims	30
Correct Optional Flame Pictures	30
Mobile Home Installation	31
Beachfire Logset Installation.....	32 - 33
Illustrated Replacement Parts	34 - 37
Warranty Statement	38
Lighting Instructions	40

Unpacking the Stove

1. Before beginning the installation, inspect the stove for shipping damage and immediately report any evidence of damage to your dealer.

2. Confirm stove contents.

The Jøtul GF 370 DV II IPI includes the following loose items shipped in the Miscellaneous Hardware bag;

- 4 mm hex key - used to remove the front glass panel for access to the firebox.
- Remote Control Transmitter
- Remote Control Wall Mount Bracket
- AA Batteries, 4
- Propane Fuel Conversion Kit 156800
- Vent Collar Grate Inserts
- Enamel Top Plate Shims, 3

3. Remove the Top Plate. Follow the instructions regarding top plate shims found in the Appendix on page 30 and fig. 63.

4. Confirm Firebox Components.

Some parts and accessories have been packed in separate boxes, and include one or more of the following items:

- Traditional Log Set 156789
- StarFire Glass 156815, Clear or 157342, Black
- River Rocks 157428
- Reflective Glass Panels 156817
- Tumbled Stones 157243

5. Remove Pallet Screw. See fig. 1.

6. Safety Screen Barriers: Two side safety barriers and one front barrier are shipped with the stove. These must be attached over the glass fire-viewing panels for protection from hot glass. Engage the safety barrier mounting tabs over the edges of the cast iron stove panels.

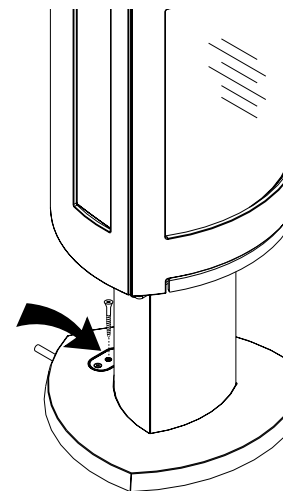

Figure 1.
Pallet screw location

Jøtul GF 370 DV II IPI Direct Vent Gas Stove

Manufactured and Distributed by:
Jøtul North America
Gorham, Maine USA

Jøtul AS
Fredrikstad, Norway

Test Standards

This appliance complies with National Safety standards and is tested and listed by Intertek Testing Services of Middleton, Wisconsin.

In addition, the Jøtul GF 370 DV II IPI has been tested and listed as a direct vent gas fireplace heater and listed to ANSI Z21.88-2019 • CSA 2.33-2019 and CAN/CGA 2.17-M91.

Specifications

Input Rates

Natural Gas

28,000 BTU/hr. maximum input

18,170 BTU/hr. minimum input

Propane

24,000 BTU/hr. maximum input

20,750 BTU/hr. minimum input

Inlet Pressure:	MIN	MAX
Natural Gas:	5.0 WC (1.24 kPa)	7.0 WC (1.74 kPa)
Propane:	12.0 WC (2.99 kPa)	14.0 WC (3.48 kPa)

Manifold Pressure:	MIN	MAX
Natural Gas:	1.6 WC (.398 kPa)	3.5 WC (0.87 kPa)
Propane:	6.4 WC (1.59 kPa)	10.0 WC (2.48 kPa)

- Steady State Efficiency: 74.41% NG / 79.30% LP
- AFUE: 68.01% NG / 68.34% LP
- CSA P4.1-15 Fireplace Efficiency:
71.14% NG / 64.13% LP
- Intermittent Pilot Ignition (IPI)
- Continuous Pilot Ignition Mode (CPI or “standing pilot”) is available.
- Power Requirement: 120 VAC for Fan, Lamp, and Burner Control Module
- Remote Control Transmitter batteries, 3, AAA - 1.5 v
- Remote Control Receiver batteries: 4, AA
- Fan Control Module: 120V / 60 Hz

Accessories

Traditional Log Set	#156789
River Rocks Set	#157428
Beachfire Logset.....	#158230
Tumbled Stones	#157243
StarFire Glass Embers, Black	#157342
StarFire Glass Embers, Clear	#156815
Reflective Glass Firebox Liner	#156817
Fuel Conversion Kit, Propane - 33% TD.....	#156800
Fuel Conversion Kit, Natural Gas - 33% TD.....	#156801
High Altitude Adjustment Kit, NG	#156822

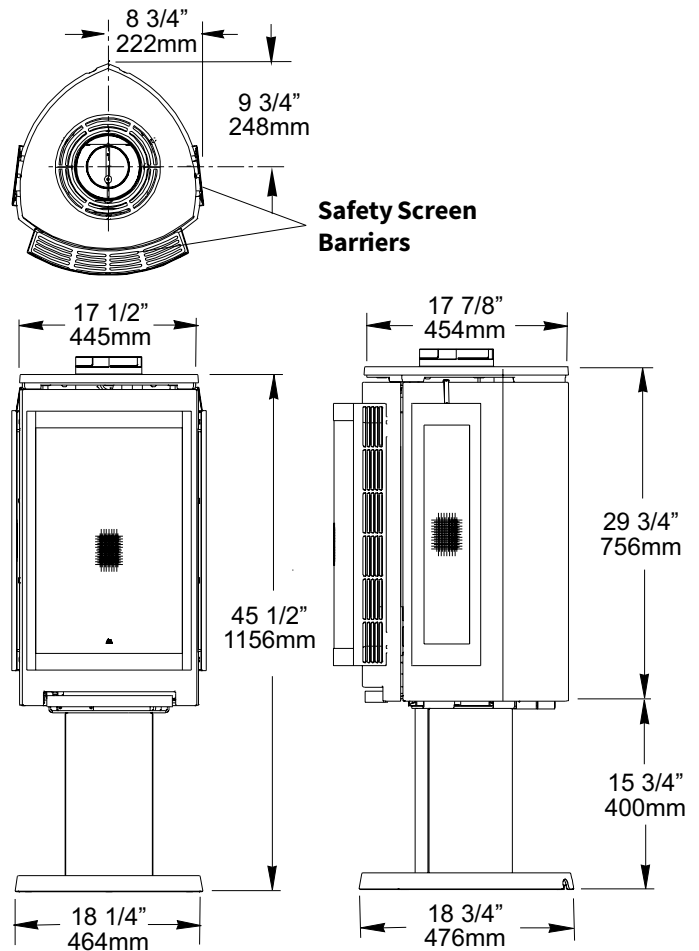

Figure 2. Overall dimensions

General Information

THIS HEATER MUST BE INSTALLED AND MAINTAINED BY A QUALIFIED SERVICE AGENCY. DO NOT ATTEMPT TO ALTER OR MODIFY THE CONSTRUCTION OF THIS APPLIANCE OR ITS COMPONENTS. ANY MODIFICATION OR ALTERATION WILL VOID THE WARRANTY, CERTIFICATION AND LISTING OF THIS APPLIANCE.

WARNING: FAILURE TO POSITION THE PARTS IN ACCORDANCE WITH THE DIAGRAMS HEREIN OR FAILURE TO USE ONLY PARTS SPECIFICALLY APPROVED WITH THIS APPLIANCE MAY RESULT IN PROPERTY DAMAGE OR PERSONAL INJURY.

IMPORTANT: SAVE THESE INSTRUCTIONS.

1. The installation and repair of this appliance must be done by a qualified service person. Failure to properly install and maintain this heater could result in an unsafe or hazardous installation, which may result in a fire, explosion, property damage, personal injury or loss of life.
2. This appliance should be inspected before use and at least annually. More frequent cleaning may be required due to excessive lint from carpeting, bedding material, etc. It is imperative that control compartments, burners and circulating air passageways of the appliance be kept clean.
3. This appliance may be installed in an aftermarket permanently located, manufactured home (USA only) or mobile home, where not prohibited by local codes. This appliance is only for use with the type(s) of gas indicated on the rating plate. This appliance is not convertible for use with other gases, unless a certified kit is used.
4. The installation must conform to local codes. Your local Jøtul authorized dealer can assist you in determining what is required in your area for a safe and legal installation. Some areas require a permit to install a gas burning appliance. Always consult your local building inspector or authority having jurisdiction to determine what regulations apply in your area.

In the absence of local codes, the installation requirements must comply with the current National codes. In the U.S., these requirements are established in the National Fuel Code, ANSI Z223.1.(NFPA 54). In Canada, the codes have been established in CAN/CGA B149 Fuel Installation Code.

5. Do not operate this fireplace if any part of it has been under water..

Immediately call a qualified service technician to inspect the heater and to replace any part of the control system and any gas control which has been under water.

6. Do not operate the fireplace with the glass front removed, cracked or broken. Replacement of the glass should be done by a licensed or qualified service person. Only remove glass for routine service. Always handle glass carefully.

Pour utilisation avec les portes en verre certifier avec l'appareil seulement ou. Ne pas utiliser avec des portes en verre.

7. Notify your insurance company before proceeding with installation of this fireplace.

FOR FUTURE REFERENCE....

Fill in the information form on page 38.

The stove serial number will be found on the shipping carton label and also on the permanent rating plate attached inside the valve compartment.

Use that page to maintain maintenance records.

Safety Information

- Due to the high operating temperatures this appliance should be located out of traffic and away from furniture and draperies. Maintain proper clearance to combustible mantels and fireplace trim.
- Children and adults should be alerted to the hazards of high surface temperatures and should stay away to avoid burns or clothing ignition.
- Young children should be supervised while they are in the same room as the appliance. Toddlers, young children and others may be susceptible to accidental contact burns. A physical barrier, such as a child guard, is recommended to be used if there are at-risk individuals in the house. To restrict access to a fireplace or stove, install an adjustable safety gate to keep toddlers, young children and other at-risk individuals out of the room and away from hot surfaces.
- A barrier designed to reduce the risk of burns from the hot viewing glass is provided with this appliance and shall be installed for the protection of children and other at-risk individuals.
- If the barrier becomes damaged, the barrier shall be replaced with the manufacturer's barrier for this appliance. See fig. 72, page 34 for part numbers.
- Any safety screen, guard, or barrier removed for servicing an appliance must be replaced prior to operating the appliance.
- Clothing or other flammable materials should not be placed on or near the fireplace.
- Never allow anyone to use the fireplace if they are unfamiliar with its operation.
- NEVER store or use gasoline or any other flammable vapors or liquids in the vicinity of this appliance.
- Never burn any solid materials (wood, cardboard, paper, coal, etc.) in this appliance. Use with natural gas or propane fuel ONLY.
- Do not slam or strike the glass panel.
- This appliance is NOT for use with aftermarket glass doors.
- Wear gloves and safety glasses while installing or performing maintenance procedures on this appliance.

WARNING!

Shock Hazard. Can cause severe injury or death. This appliance is powered by line voltage. Do not try to repair the components in this appliance. In no way are the component enclosures to be tampered with or opened. Disconnect from line voltage during installation or performing any maintenance.

ATTENTION!

- Shut off the main gas supply to the appliance during receiver or remote control battery replacement.
- Always shut off the main gas supply to the appliance during inspection, maintenance, or cleaning.

Electrical Hazards

- Be aware of electrical wiring locations when cutting holes in walls and ceilings for termination.
- This appliance power supply must be electrically grounded in accordance with local codes or, in the absence of local codes, with the current ANSI/NFPA 70, National Electrical Code or CSA C22.1-Canadian Electrical Code.
- This appliance power supply incorporates a three-prong (grounding) plug for protection against shock hazard and should be plugged directly into a properly grounded three-prong receptacle. **DO NOT CUT OR REMOVE THE GROUNDING PRONG FROM THE PLUG.**
- Do not disconnect the lamp and fan power cords from the appliance power supply (Fan Control Module). Use the rocker switch to control power to these parts.
- Always disconnect (unplug) the main power supply from its outlet when performing routine service on this appliance.

Installation

Stove Location

In selecting a location for the stove, consider the following points:

- 1) Heat distribution
- 2) Vent termination requirements
- 3) Gas supply routing
- 4) Traffic areas, furniture, draperies, etc.
- 5) 120V electrical outlet availability

This stove may be located on or near conventional construction materials, however, proper clearance to combustibles must be maintained in order to provide adequate air circulation around the appliance. Also, it is important to provide adequate access around the stove for servicing and proper operation.

The clearances specified in this manual are the minimum requirements established as a result of safety testing. A combustible material is anything that can burn; i.e. sheet rock, wall paper, wood, fabrics, etc. These surfaces are not limited to those that are visible and also include materials that may be located behind non-combustible materials.

If you are not sure of the combustible nature of a material, consult your local fire officials. "Fire-resistant" materials are considered to be combustible. They may be difficult to ignite, but will burn. "Fire-rated" sheet rock is also considered combustible.

Hearth Requirements

The Jøtul GF 370 DV II IPI has been approved for installation directly on combustible floor materials. No additional floor protection is required, however, we recommend that the stove be installed on a solid surface.

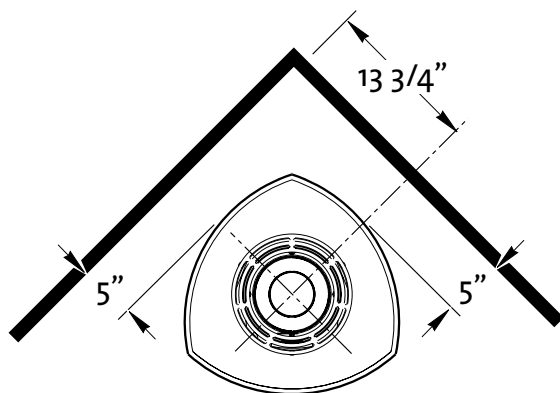

Figure 3. Corner Clearances.

Stove and Vent Clearance Requirements

Clearance is measured from the stove body as illustrated - not the Safety Barriers.

Minimum Clearances: See figs. 3-5.

Rear: 3" (76 mm) - from Rear of the unit

Ceiling: 16 3/4" (425 mm) - from Stove Top

Corner: 5" (127 mm) - from Stove Top

Sides: 7" (178 mm) - from Stove Top

Minimum Clearances from the Vent Pipe to Combustibles:

Horizontal Run:

Off the top of the pipe - 2" (51 mm) Alcove - 7" (178 mm)

Off the sides and bottom - 1" (25 mm)

Vertical Run: All sides - 1" (25 mm)

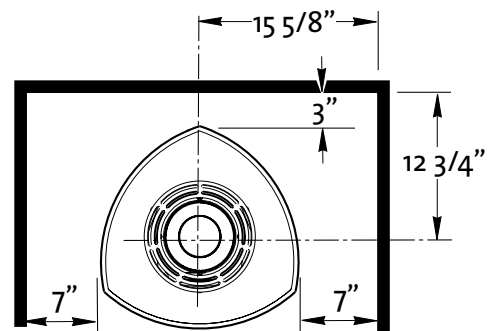

Figure 4. Alcove and Wall Clearances.

ALCOVE SPECIFICATIONS:

Maximum Alcove Depth:	21 3/4" (55.2 cm)
Minimum Alcove Width:	31 1/4" (79.3 cm)
Minimum Ceiling Height:	62 1/4" (158.1 cm)

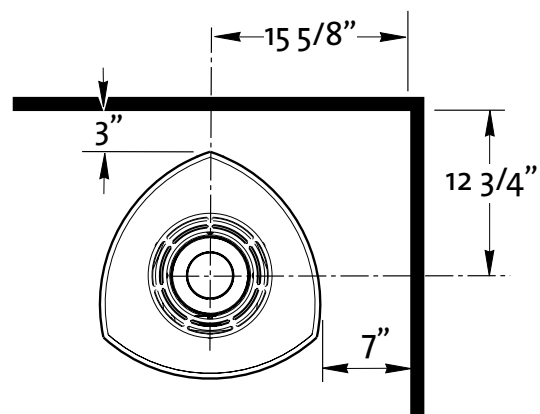

Figure 5. Parallel Wall Clearances.

Venting Requirements

There are three types of venting configurations approved for use with this appliance:

- Vertical Venting / Vertical Termination
- Vertical Venting / Horizontal Termination
- Horizontal Venting / Snorkel Termination

This appliance is approved for use with the 4/6 direct vent systems manufactured by the companies listed on page 8. Use parts of one manufacturer only - DO NOT MIX VENT COMPONENTS FROM DIFFERENT MANUFACTURERS WITHIN THE SAME SYSTEM.

Installation of any components not manufactured or approved by Jøtul or failure to meet all clearance requirements will void all warranties and could result in property damage or bodily injury.

The approved vent configurations described in this manual are derived from extensive testing under controlled laboratory conditions. Gas appliance performance can be negatively affected by variables present in the installation environment, i.e.; atmospheric pressure, strong prevailing winds, adjacent structures and trees, snow accumulation, etc. These conditions should be taken into consideration by the installer and stove owner when planning the vent system design.

Approved Vent Manufacturers

The Jøtul GF 370 DV II IPI stove is approved for installation with direct vent chimney components supplied by the following manufacturers:

M&G DuraVent, Inc. (Direct Vent Pro Series)

P.O. Box 1510
Vacaville, CA 95696-1510 800-835-4429

Selkirk Corporation

1301 W. President George Bush Hwy, Suite 330
Richardson, TX 75080-1139 800-992-8368

American Metal Products (Amerivent)

8601 Hacks Cross Rd.
Olive Branch, MS 38654 800-423-4270

Security Chimneys International Limited

2125 Monterey, Laval, Québec
Canada, H7L 3T6 450-973-9999

Metal-Fab, Inc. (Sure-Seal Direct Vent)

P.O. Box 1138
Wichita, KS 67201 316-943-2351

ICC, Inc.

400 J-F Kennedy St. Jerome, Quebec
Canada, J7Y 4B7 450-565 6336

Bernard Dalsin Manufacturing Co. (Pro Form)

5205 208th Street West
Farmington, MN 55024 651- 460-1080

Olympia Chimney Supply Inc.

600 Sanders Street Suite 2
Scranton, PA 18505-3400 570-496-8890

IMPORTANT

- **JOINT SEALING REQUIREMENT:** APPLY A 1/8" BEAD OF HIGH-TEMPERATURE SEALANT OR MIL-PAC® TO THE MALE SECTION OF THE INNERVENT PIPE. THE CEMENT SHOULD FORM A SEAL BETWEEN THE INNER AND OUTER PIPES. **DO NOT USE SILICONE.** SEE FIG. 6. SEE VENT MANUFACTURER'S INSTRUCTIONS.
- NEVER MODIFY ANY VENTING COMPONENT, OR USE ANY DAMAGED VENTING PRODUCT.
- THE GAS APPLIANCE AND VENT SYSTEM MUST BE VENTED DIRECTLY TO THE OUTSIDE OF THE BUILDING AND NEVER ATTACHED TO A CHIMNEY SERVING A SOLID FUEL OR GAS BURNING APPLIANCE. EACH DIRECT VENT GAS APPLIANCE MUST HAVE ITS OWN SEPARATE VENT SYSTEM. COMMON VENT SYSTEMS ARE PROHIBITED.
- IF VENTING SYSTEM IS DISASSEMBLED FOR ANY REASON, REINSTALL PER THE MANUFACTURER'S INSTRUCTIONS PROVIDED FOR THE INITIAL INSTALLATION.

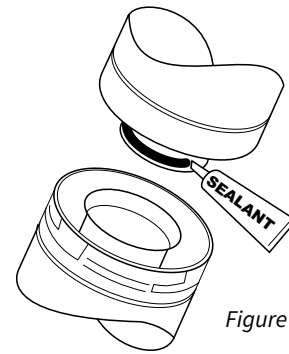

Figure 6.

Vertical Venting and Termination

The Jøtul GF 370 DV II IPI can be vertically vented through a roof or ceiling. Follow these guidelines

- Steep roofs, nearby trees, or predominantly windy conditions, can promote poor draft or down draft conditions. In such cases, an increase to the height of the vent may improve performance.
- If an offset or elbow is necessary in the vertical rise, the vent pipe must be supported every three feet to avoid excessive stress on the offsets. Use listed Wall Straps from any of the approved vent suppliers.
- A maximum of two 90° or four 45° elbows may be used in a vertical termination. Whenever possible, use 45° elbows instead of 90° elbows as they offer less restriction to the flow of flue gases and intake air.
- A listed firestop is required at any floor penetration. The opening should be framed in according to the manufacturer's instructions.
- Always maintain a minimum 1" clearance from all sides of the vertical vent system to any combustible material.
- Minimum vertical termination height: 6 ft. of vent pipe.

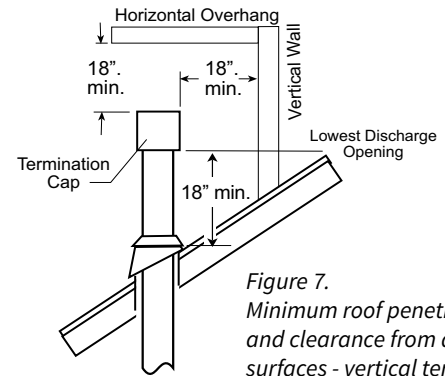

Figure 7.
Minimum roof penetration height and clearance from adjacent surfaces - vertical termination.

- IT IS NECESSARY to add restriction to a vertical vent installation to compensate for excessive draft. See page 13; Exhaust Restriction Adjustment.
- GAS VENT HEIGHT: In no case shall any discharge opening on the cap be less than 18" (457 mm) horizontally from the roof surface. See fig. 7.
- Maximum Vent Height: 35 ft. above the appliance.

Horizontal Termination

- **Minimum vertical rise** from the vent collar is a 24" section vent pipe. See fig. 9. Minimum horizontal run is 12" with natural gas and 18" with propane.
- A maximum of two 90° or four 45° elbows may be used in a horizontal termination. Whenever possible, use 45° elbows instead a 90° elbow as they offer less restriction to the flow of flue gases and intake air.
Reduce the overall horizontal run by 5 feet for each additional elbow, whether 45° or 90°.
- **Snorkel Termination - (14" or 36"): NATURAL GAS ONLY. DO NOT USE SNORKEL TERMINATION WITH PROPANE FUEL.**
A horizontal vent run may be made with a 90° elbow directly to the rear of the stove only when terminated by a 14 or 36 inch snorkel cap. Fig. 10 shows the minimum vent pipe requirements.
14" Snorkel: The maximum horizontal vent run must not exceed a 24" section of pipe and must be a minimum of 12".
36" Snorkel: The maximum horizontal vent run must not exceed 5 feet and must be a minimum of 12".
- **The termination cap must not be recessed into the wall or siding.** Do not fill air space in wall around termination cap with any type of insulation.
- **Wall Cut-out:** A minimum 10" X 10" square hole is adequate for proper pipe clearance through a wall, provided the vent is positioned to maintain 2" minimum clearance at the top. A 1" minimum clearance must be maintained to combustible material around the other sides. See fig. 11.
- Any horizontal run of vent must have a 1/4" rise for every foot of run toward the termination cap.
- All horizontal terminations must comply with the clearance specifications to adjacent structures as indicated in fig. 12.
- **Installation of a Vinyl Siding Standoff is required** to prevent damage to vinyl siding between the vent cap and the exterior wall.
- **A horizontal termination cap must maintain a 3" clearance to any overhead combustible projections that are 2 1/2" or less.** It must also maintain a 12" clearance from projections that exceed 2 1/2". See fig. 13.
Vinyl siding projections require a default clearance of 18" to the vent terminal.
- **A vent shall not terminate where it could cause hazardous frost or ice accumulations on adjacent property surfaces.**

Figure 9. Minimum vent pipe sections required for horizontal termination:
A = 12" with NG
18" with LP

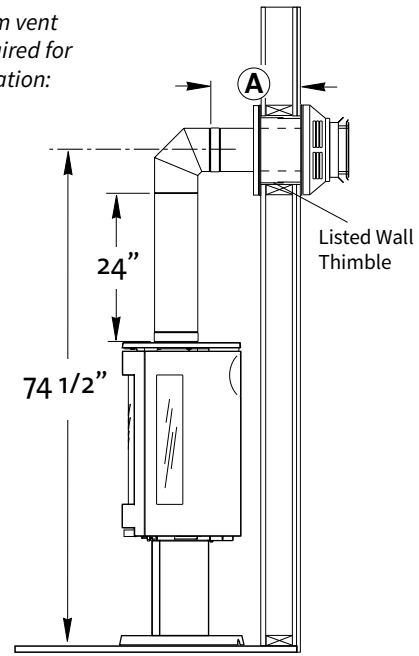

Figure 10. Minimum vent pipe sections required for a 14" Snorkel termination - Natural Gas ONLY.

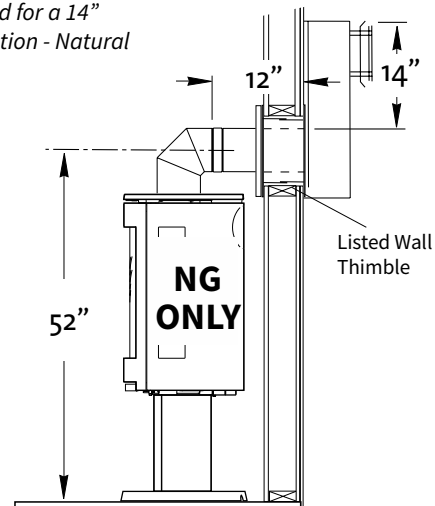
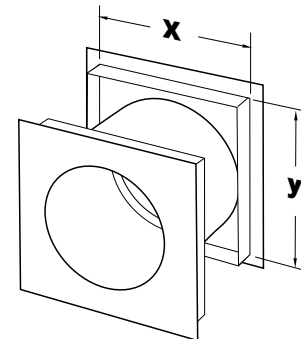

Figure 11. Install a listed wall thimble according to manufacturer's instructions to maintain required clearance to combustible materials.



Horizontal Termination Clearance

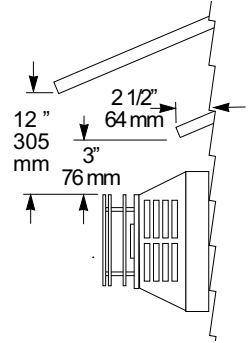
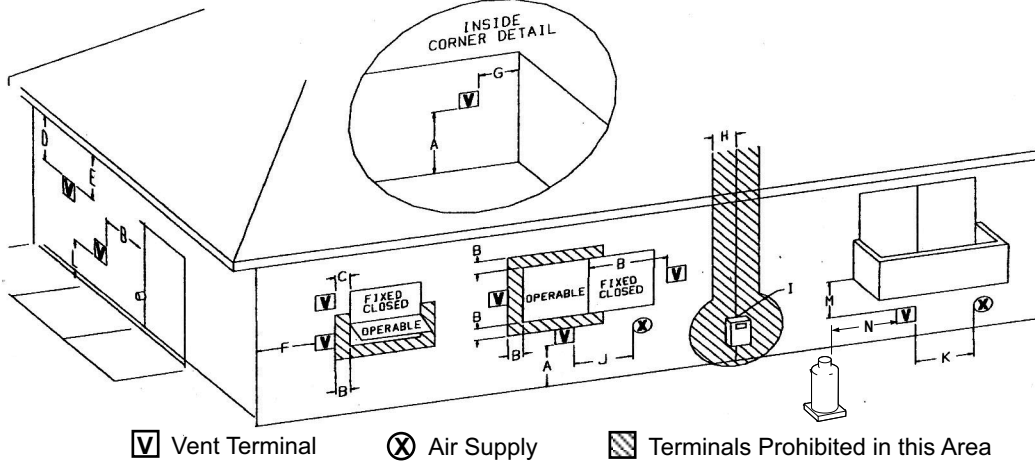

Figure 13. Termination Clearance to overhangs.

Figure 12. Vent Terminal Clearances - ANSI Z21.88-2019, CSA 2.33-2019, and NFPA 54 / ANSI Z223.1 National Fuel Gas Code.

		Canadian Installations ¹	U.S. Installations ²
A	Clearance above grade, veranda, porch, deck, or balcony	12 in. (30 cm)	12 in. (30 cm)
B	Clearance to window or door that may be opened	12 in. (30 cm)	9 in. (23 cm) We recommend 12 in. to prevent condensation on a window.
C	Clearance to permanently closed window	12 in. (30 cm)	9 in. (23 cm) We recommend 12 in. to prevent condensation on a window.
D	Vertical clearance to ventilated soffit located above the terminal within a horizontal distance of 2 ft (60 cm) from the center line of the terminal	18 in. (46 cm)	18 in. (46 cm)
E	Clearance to unventilated soffit	12 in. (46 cm)	12 in. (46 cm)
F	Clearance to outside corner	12 in. (46 cm)	9 in. (23 cm) We strongly recommend 12 in. particularly where strong winds prevail.
G	Clearance to inside corner	12 in. (46 cm)	9 in. (23 cm) We strongly recommend 12 in. particularly where strong winds prevail.
H	Clearance to each side of center line extended above a gas meter or regulator	3 ft. (91 cm) within a height 15 ft. above the meter/regulator assembly	*
I	Clearance to service regulator vent outlet	3 ft. (91 cm)	*
J	Clearance to nonmechanical air supply inlet to building or the combustion air inlet to any other appliance	12 in. (30 cm)	9 in. (23 cm)
K	Clearance to a mechanical air supply inlet	6 ft. (1.83 m)	3 ft. (91 cm) above if within 10 ft. (3 m) horizontally
L	Clearance above paved sidewalk or paved driveway located on public property	7 ft. (2.13 m) ²	7 ft. (2.13 m)*
M	Clearance under veranda, porch, deck, or balcony	12 in. (30 cm) ³	12 in. (30 cm) ³
N	Clearance to propane tank relief valve and filler connection	5 ft. (1.52 m) ⁴ / 10 ft. (3.05 m) ⁵	5 ft. (1.52 m) ⁴ / 10 ft. (3.05 m) ⁵

1) In accordance with the current CSA B149.1, Natural Gas and Propane Installation Code.

2) In accordance with ANSI Z223.1/NFPA 54, National Fuel Gas Code

* For clearances not specified in ANSI Z223.1/NFPA or CSA B149.1, the clearance will be in accordance with local installation codes and the requirements of the gas supplier and these installation instructions.

3) Permitted only if veranda, porch, deck, or balcony is fully open on a minimum of two sides beneath the floor.

4) Minimum clearance to tanks not filled on site.

5) Minimum clearance to tanks filled on site from bulk truck.

Vent Restriction Adjustments

The Jøtul GF 370 DV II IPI features adjustment controls for both intake air and exhaust to accommodate a variety of conditions that result from variables inherent in the vent configuration and environment. Both controls can be accessed from outside the firebox to allow the burner to be “dialed-in” under operation. See figures 14 and 16.

Use the Vent Termination Diagram, fig. 17, to determine which zone your vent termination falls within and make the appropriate exhaust and air intake setting adjustments. Use these settings as general guidelines to start from. The final settings will ultimately be determined by the individual characteristics of your particular installation. There are no hard and fast rules.

Exhaust Vent Restriction

Exhaust restriction prevents overly strong draft that can interfere with pilot function, cause poor combustion or a weak flame picture. The shutter is set in the fully open position at the factory. The final position of the restriction shutter is determined by where the vent termination falls within the vent window diagram.

For example, if the vent rise is 20 feet and includes one elbow in a horizontal run of 5 feet, the appropriate exhaust setting will be Full Restriction.

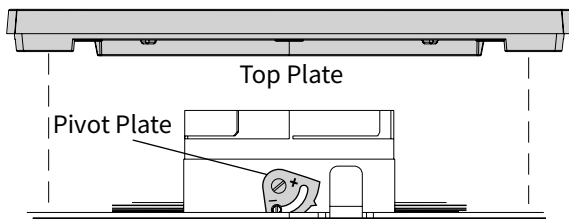

Figure 14. The Exhaust Restrictor is located within the vent adaptor collar.

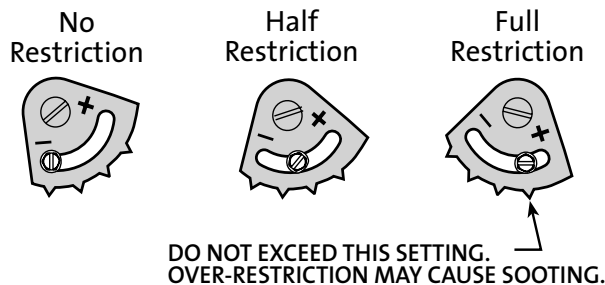

Figure 15. Exhaust Restrictor settings

Exhaust Restrictor Adjustment

1. Remove the Trim Rings from the Top Plate.
2. Loosen the locking screw and turn the restrictor pivot plate to the appropriate indicator point as specified in the vent window diagram, figure 17. After the burner has been operating for 15 minutes, make any further adjustment in 1/8” increments until the desired flame picture is achieved. **Do not exceed the fully closed setting as shown in fig. 15.** Operate the burner for 10-15 minutes between additional adjustments.
3. Tighten the locking screw and replace the Trim Rings.

Intake Air Adjustment

An Intake Air shutter plate allows further burner adjustment for taller vent runs. It is located under the firebox floor and is set fully open at the factory. See fig. 16.

The shutter has an adjustment range of 1 inch. To change the setting, loosen the wingnut and slide the gasketed shutter stem backward to the half or fully closed positions, depending on which vent zone is appropriate. Retighten the wingnut before lighting the burner to seal the gasket. Allow the flame pattern to settle in for 10- 15 minutes between each setting change.

Zone D

Vent terminations within Zone D are susceptible to draft conditions that may interfere with the intermittent Pilot Ignition functionality. In such cases, we recommend that the stove be operated only in Continuous Pilot Ignition mode.

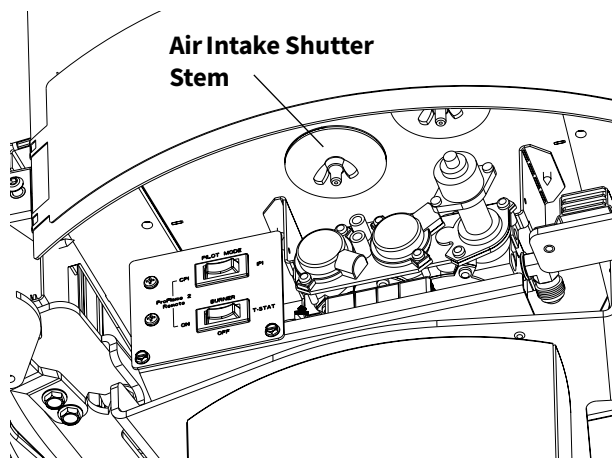

Figure 16. Air intake shutter location.

- A maximum of two 90° or four 45° elbows may be used. Whenever possible, use 45° elbows instead of 90° elbows as these offer less restriction to the flow of flue gases and intake air. Use of elbows may adversely affect IPI functionality. In such cases, CPI mode should be used.
- Reduce the overall horizontal run by 5 feet for each additional 45° and 90° elbow.
- When two or more elbows are used in a horizontal run, a less restricted setting may be more effective than that indicated by the termination zone diagram.

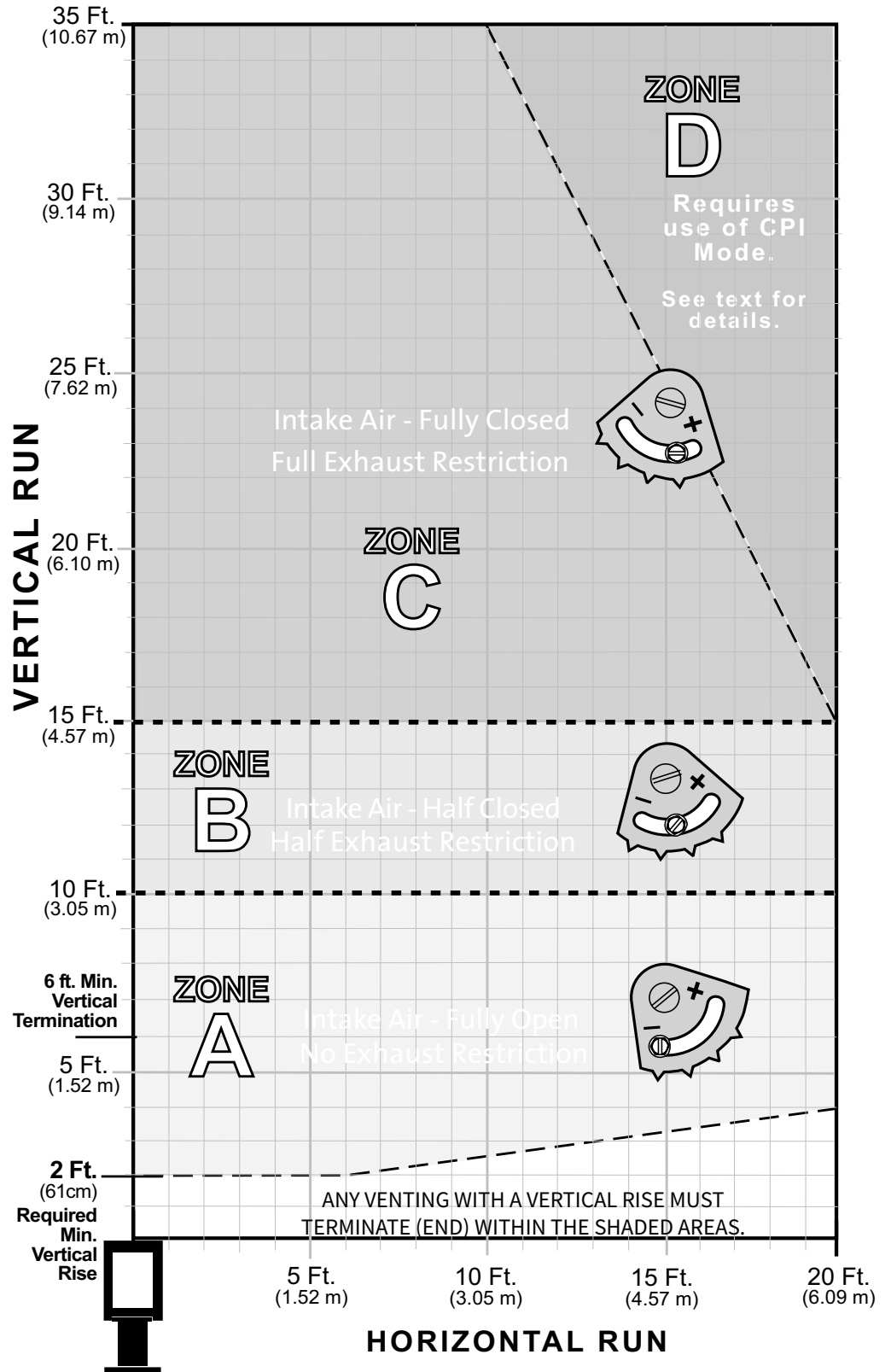

Figure 17. Vent Termination Diagram.

Stove Assembly

1. Glass Frame Removal

To access the firebox, use the 4 mm hex key to remove the four socket head screws that attach the glass frame to the firebox. See fig. 18.

- Remove the labeled lower skamol retainer from the firebox and discard.

2. Routing the Power Supply

The power cord located in the valve compartment is connected to the Fan Control Module which is the main power supply for all stove operating functions. Route the cord through the pedestal and out the rear of the pedestal base as in fig. 18, or through the floor.

CAUTION: Take care that the pedestal base does not pinch the power cord. You should be able to feel free play in the cord.

The 10 foot extension power cord, supplied in the hardware bag, is intended to connect the interior cord to the nearest 120V house current outlet.

DO NOT CONNECT THE STOVE TO HOUSE CURRENT UNTIL THE INSTALLATION IS COMPLETE AND YOU ARE READY TO INITIATE THE FIRST BURN.

3. Connecting the Gas Supply

Gas Supply Requirements

ALL INSTALLATIONS MUST COMPLY WITH LOCAL CODE OR IN THE ABSENCE OF LOCAL CODE, MUST COMPLY WITH THE MOST RECENT EDITION OF THE NATIONAL FUEL GAS CODE ANSI Z223.1/NFPA 54 OR CAN-B149.

THIS PRODUCT MUST BE INSTALLED BY A LICENSED MASTER OR JOURNEYMAN PLUMBER OR GAS-FITTER WHEN INSTALLED IN THE COMMONWEALTH OF MASSACHUSETTS.

Shut-off Valve

All codes require a gas shut-off valve (gas cock) and union to be installed in the supply line within 6 feet of the appliance. This allows for the disconnection of the stove for servicing and maintenance. See Fig. 19.

A T-HANDLE GAS SHUT-OFF VALVE IS REQUIRED IN MASSACHUSETTS IN COMPLIANCE WITH CODE 248CMR.

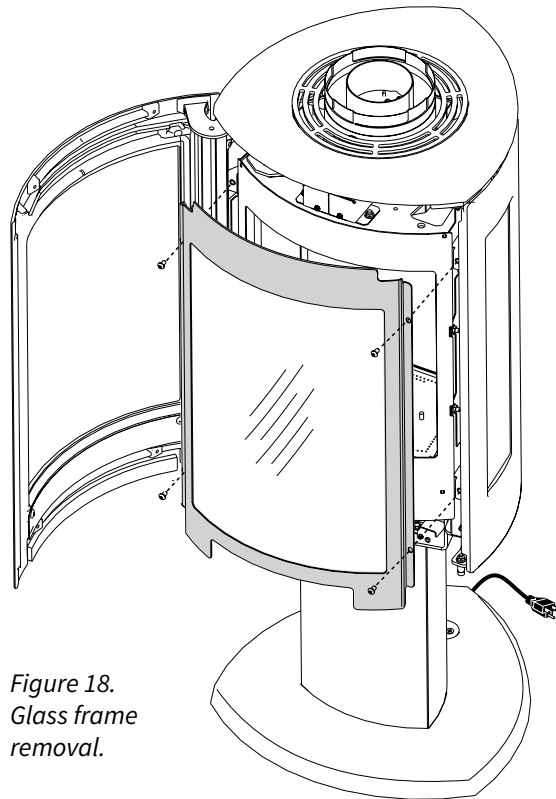

Figure 18.
Glass frame removal.

The stove and gas control valve must be disconnected from the gas supply piping during any pressure testing of the system at test pressures in excess of 1/2 psig. For pressures lower than 1/2 psig, isolate the gas supply by closing the manual shut-off valve.

Control Valve Connection

The gas supply line connection to the stove flex line can be made at the rear of the base plate or through the floor. The gas supply line should be a minimum 3/8" inside diameter, or the appropriate size to provide sufficient gas pressure to the valve regardless of the input setting.

The use of flexible gas appliance connectors is acceptable in many areas in the U.S. In Canada, methods vary depending on local code. If local codes permit, use flexible gas line for ease of installation and service. For those locales where flexible gas lines are not permitted, use the 3/8" iron fitting to make the connection at the top side of the Control Valve. See fig. 19.

Secure all joints tightly using appropriate tools and sealing compounds (for propane units, be sure to use compounds that are propane resistant). Turn on gas supply and test for gas leaks using a 50/50 soapy water solution or a gas detector.

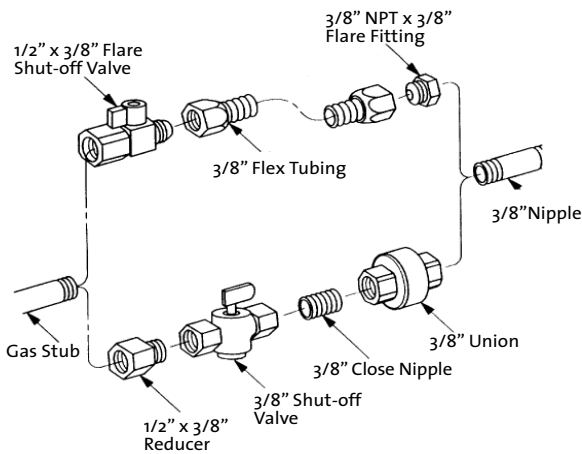

Figure 19. Gas supply valve types and fittings.

NEVER USE AN OPEN FLAME TO CHECK FOR GAS LEAKS.

ALWAYS REFER TO THE LIGHTING INSTRUCTIONS ON THE INSIDE BACK COVER OF THIS MANUAL WHEN LIGHTING THE STOVE.

Soap Solution Leak Test

- Mix a 50-50 solution of water and dish soap.
- Light appliance - see lighting instructions on the back cover of this manual or on the rating plate.
- Brush or spray all joints and connections with the soapy water solution.
- If bubbles appear at any connection or seam or a gas odor is detected, immediately turn gas control knob to the OFF position.
Tighten or reconnect the leaking joint and retest for any gas leaks.

4. Testing Gas Pressure

Proper gas pressure provides a consistent flow of gas to the appliance and is instrumental in checking for gas leaks. There are two pressure test points on the front of the stove control valve where test gauge connections are made. See Fig. 20. Gauge connections are identified by:

- E for inlet or supply pressure (the amount of gas coming to the valve.)
- A for manifold pressure (the amount of gas that is coming out of the valve to the burner.)

The line must be disconnected from the gas supply line by closing the main supply manual gas shut-off valve (gas cock) during any pressure testing of the gas supply piping system that is equal to or exceeds pressures of 1/2 psig (3.5 kPa).

Inlet Pressure

MIN _____ MAX

Natural Gas: 5.0 WC (1.24 kPa) 7.0 WC (1.74 kPa)
Propane: 12.0 WC (2.99 kPa) 14.0 WC (3.48 kPa)

Manifold Pressure

MIN _____ MAX

Natural Gas: 1.6 WC (0.398 kPa) 3.5 WC (.87 kPa)
Propane: 6.4 WC (1.59 kPa) 10.0 WC (2.48 kPa)

ALWAYS TEST PRESSURES WITH VALVE REGULATOR CONTROL AT THE HIGHEST SETTING.

Symptoms of incorrect gas pressure include:

Insufficient gas pressure:

- Small pilot flame which can result in insufficient millivolts.
- Little variation in flame picture between HI and LO regulator settings.
- Insufficient gas to support more than one appliance causing nuisance outages or gas surges.

Excessive gas pressure:

- Permanent damage to valve causing complete appliance shut down.
- Too large a pilot flame resulting in overheating of the power generator and consequent shut down.
- Sooting due to impingement and/or incorrect fuel to air mix.

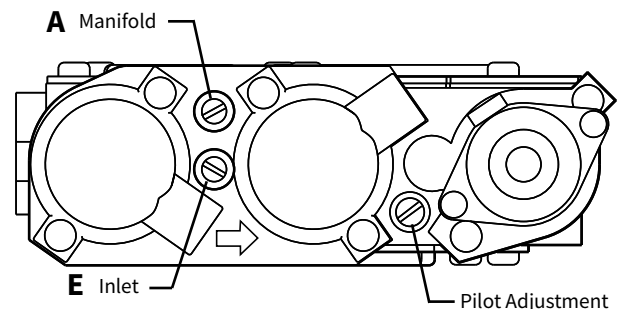

Figure 20. Pressure test points located on the front of the valve.

WARNING

DO NOT ALLOW THE INLET GAS PRESSURE TO EXCEED 14.0" WC (OR 1/2 PSIG) AS SERIOUS DAMAGE TO THE VALVE MAY RESULT.

5. Fuel Conversion

The GF 370 DV II IPI gas stove is shipped from the factory equipped to burn Natural gas. Propane fuel conversion kit 156800 is included with the stove to enable use with LP gas if necessary. The kit contains all the components needed to complete the task and ensure safe operation, including labels that must be affixed to the stove.

CAUTION: Before proceeding with this conversion, the gas supply must be shut off prior to disconnecting the electrical power.

This conversion kit shall be installed by a qualified service agency in accordance with the manufacturer's instructions and all applicable codes and requirements of the authority having jurisdiction. If the information in these instructions is not followed exactly, a fire, explosion, or production of carbon monoxide may result causing property damage, personal injury or loss of life. The qualified service agency is responsible for the proper installation of this kit. The installation is not proper and complete until the operation of the converted appliance is checked as specified in the manufacturer's instructions supplied with the kit.

Cet équipement de conversion sera installé par une agence qualifiée de service conformément aux instructions du fabricant et toutes exigences et codes applicables de l'autorisés avoir la juridiction. Si l'information dans cette instruction n'est pas suivie exactement, un feu, explosion ou production de protoxyde de carbone peut résulter le dommages causer de propriété, pert ou blessure personnelle de vie. L'agence qualifiée do service est esponsable de l'installation propre de cet équipement. L'installation n'est pas propre et complète jusqu'à l'operation de l'appareil converi est chéque suivant les critères établis dans les instruction de propriétaire provision nées avel l'équipement.

Conversion Kit (LP #156800, NG #156801)

Tools required:

- 1/2" & 13 mm open end wrench or deep-well socket
- Torx T20 or slotted screwdriver
- 7/16" open end wrench
- 1/4" nut driver
- 4 mm allen wrench

Conversion Kit Contents:

- 1 regulator tower labeled for the appropriate fuel
- 2 regulator tower Torx screws
- 1 burner injector (#38 mm for NG, #53 for LP)
- 1, pilot Injector - BL .020 for NG - 226758
.013 for LPG - 226759
- Label A - to be completed and applied to the base of the valve compartment

- Label B - apply to the rating plate in the space indicated on the plate.
- Small valve label - apply to valve body
- Conversion instructions

Fuel Conversion Procedure

1. Turn off gas supply to the stove and disconnect from electrical power source.
2. Remove the glass frame. See fig. 18.
3. Loosen the primary air shutter wingnut and push the stem all the way back. Fig. 21.

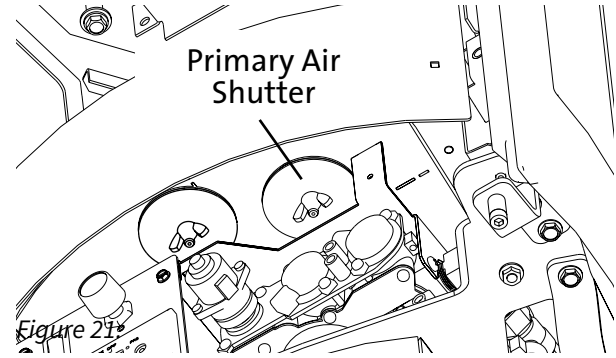

Figure 21. Air Shutter location.

4. Pull the Burner Plate forward to disengage it from the burner orifice and lift it out of the firebox.
5. Locate the main burner injector. See fig. 23 on page 17. Slide the Air Shutter out of the way and use a 1/2" open end wrench or deep-well socket to remove the burner orifice from the brass orifice holder. Replace with the orifice supplied in the kit. **CAUTION: Do NOT over tighten the Burner Injector. Over tightening can damage the brass elbow and cause a gas leak!**
6. Change the Air Shutter position: Lift the shutter tube up in its hinge pin slots and turn the tube over, so that the appropriate fuel type indicator (LP or NG) is oriented facing you. See fig. 22. Push the shutter all the way back over the injector.
7. Change the Pilot Injector, Fig. 23 A.
 - Use a 1/4" nut driver to remove the sheet metal screws and Pilot Shield from the pilot assembly.
 - Use the 7/16" wrench to remove the pilot head base.
 - Remove the pilot injector from pilot base and replace with the one in the fuel conversion kit.

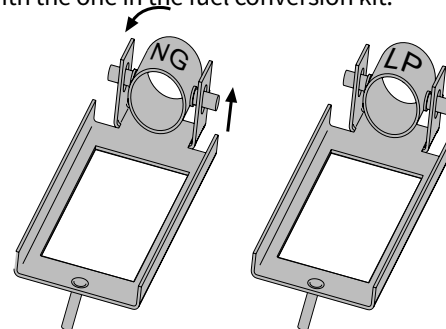
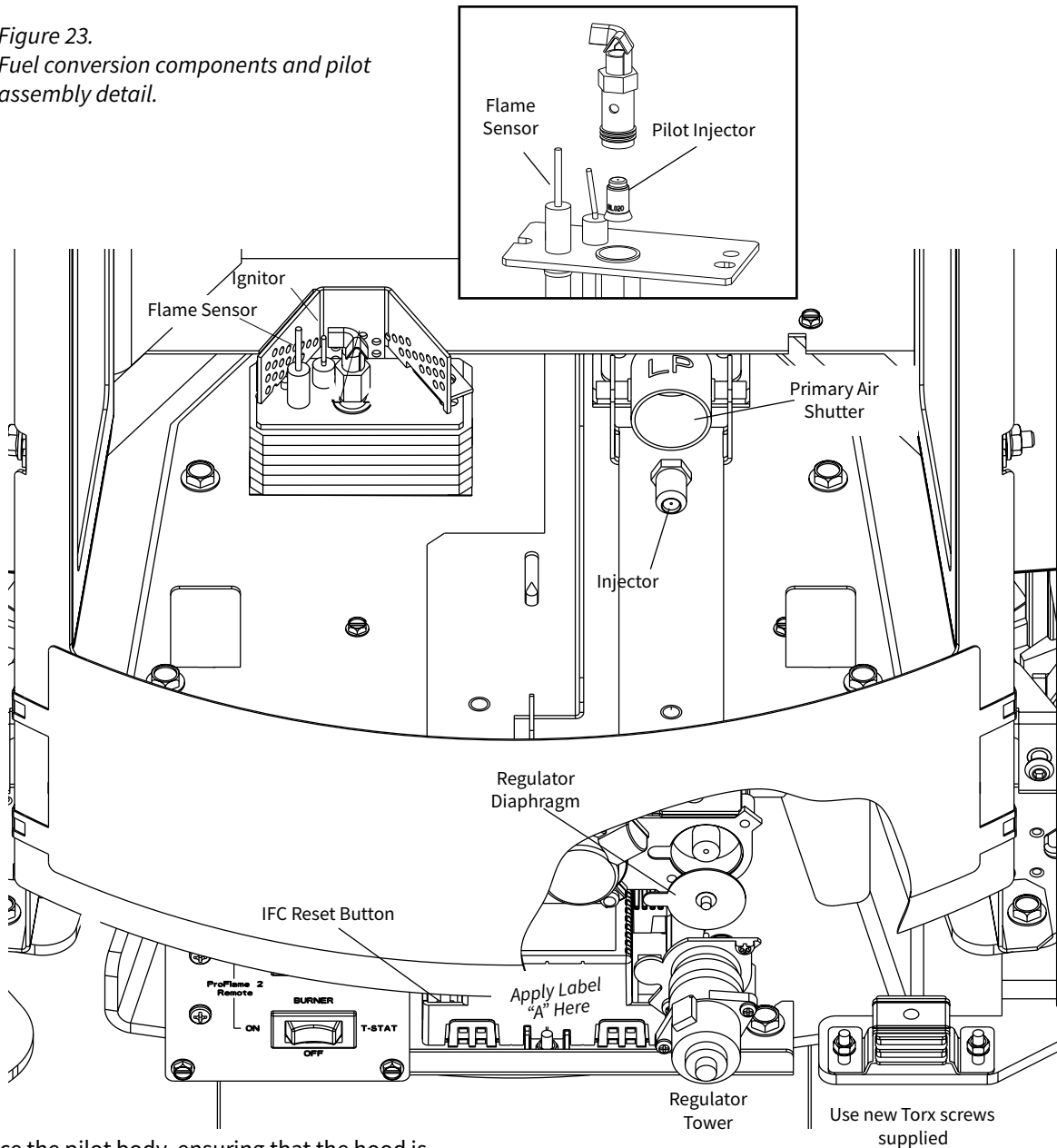

Figure 22. Primary air shutter orientation must be changed for fuel type.

Figure 23.
Fuel conversion components and pilot
assembly detail.



- Replace the pilot body, ensuring that the hood is oriented to direct flame to the Flame Sensor and burner pilot carry-over ports. Tighten the pilot base nut and replace the pilot shield.
8. Reinstall the Burner Plate by engaging the venturi tube with the Air Shutter. BE CERTAIN THE BURNER IS LEVEL AND SECURELY SEATED ON THE SUPPORT LEGS ON THE FIREBOX FLOOR.
 9. Replace the variable regulator. Using a Torx T-20 screwdriver, remove the two specialty screws from the regulator tower on the front of the valve. Note: To help identify which screws to remove, refer to the new regulator in the kit. See fig. 23.
 10. Disconnect the Regulator wire lead from the receptacle housing terminal. Remove the regulator tower and the rubber diaphragm.
 11. Install the new variable regulator tower from the kit. Be sure that the gasket is properly positioned and tighten screws securely. Connect the wire lead.
 12. Apply the identification labels to the stove so that they can be seen by any person that may be servicing the stove.
 - Label "A": Apply to front lip of the valve compartment.
 - Label "B": Apply to the Rating Plate.
 - Small valve sticker: Apply to valve.
 13. Install the accessory panels and burner media as appropriate. See pages 19-21.
 14. Apply anti-seize lubricant to the socket head glass frame screws before reinstalling the glass frame.
 15. Apply gas to the system and check for leaks using a soapy water solution or gas sensor.
 16. Follow the System Check instructions on pages 22-23 for initial start-up and flame picture adjustment.

6. High Altitude Adjustment

The decreased atmospheric pressure of higher altitudes affects heat value of gaseous fuels. Most gas suppliers derate the gas intended for use at elevations above 2000 feet. Check with your gas supplier before performing derate adjustment to the burner.

This appliance may be adjusted for altitude over 2000 ft. (610 - 1371 m) for natural gas. If the gas supplier does not derate fuels, install High Altitude Adjustment Kit 156822 for Natural gas.

DO NOT DERATE FOR PROPANE.

U.S & Canada per ANSI Z21.88-2005-CSA 2.33-2005, CAN/CGA 2.17

For natural gas installations from 610-1370 meters (2000-4500 ft.) the orifice size (DMS) is #39. See data plate for additional information. For high altitude installations consult the local gas distributor or the authority having jurisdiction for proper rating methods. If the installer must convert the unit to adjust for varying altitudes, the information sticker must be filled out and applied to the appliance at the time of the conversion.

Cet appareil est équipé pour des altitudes comprises entre 0 et 2000 pieds (0-610 m) seulement.

Derating Procedure

- Follow Steps 1-6 of the Fuel Conversion procedure on pages 16 to change the burner injector. Use the injector supplied with the kit. Detailed instructions are also included in the kit.
- Conduct gas leak and gas pressure tests as detailed on page 15 of this manual.
- Conduct system check and flame picture adjustments as specified on pages 22-23.

INSTALLER: Fill out the appropriate information and apply the high altitude conversion label provided to the rating plate on the appliance. See fig. 24.

This appliance has been converted for use at an altitude of _____ . Orifice Size: _____ Manifold Press. _____ Input Btu/Hr. _____ Fuel Type _____ Date: ___/___/___ Converted by: _____ Cet appareil a été converti au _____ Injecteur _____ Pression à la tubulure d'alimentation _____ Débit calorifique _____
--

Figure 24. High Altitude Conversion Label.

7. Firebox Panel Installation

Skamol Panels and optional Reflective Glass Kit 156817

Skamol Panels

These insulating panels are installed at the factory. If desired, the panels may be painted black using any high-temperature paint.

THE SKAMOL PANELS MUST BE LEFT IN PLACE. DO NOT OPERATE THE STOVE WITHOUT THE SKAMOL PANELS INSTALLED.

Reflective Glass Panels

Tools: 1/4" socket driver

Optional: High-temp Black Paint may be applied to the exposed edges of the side Skamol panels to match the black glass.

Cotton gloves are provided with the glass panels. Use them to handle the panels to prevent fingerprints on the surfaces. Fingerprints are difficult to remove. Use a clean cloth to remove any dust from the glass panels.

1. Remove the Upper Retainer Bracket from the firebox with removal of three #8 x 12 sheet metal screws. See fig. 25.
2. Remove the Lower Panel Retainer from the back of the burner skirt with removal of three #8 x 12 sheet metal screws.
3. **Orient the rear panel, smooth side out, textured side in.** Rest the bottom of the panel on the burner skirt, centered against the back wall. See fig. 26.
4. Orient the side panels, smooth side out, and sliding each behind the retainer wings. See Fig. 26a.
5. Push the Upper Retainer back against the glass panels and tighten the three sheet metal screws.
6. Replace the Lower Panel Retainer.

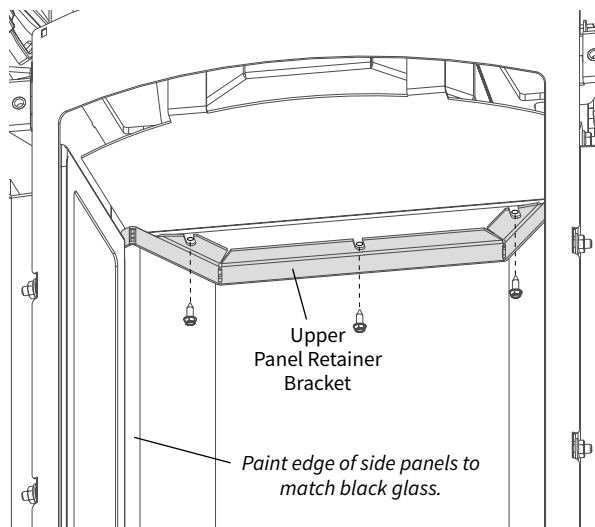

Figure 25. Loosen the panel retainer screws.

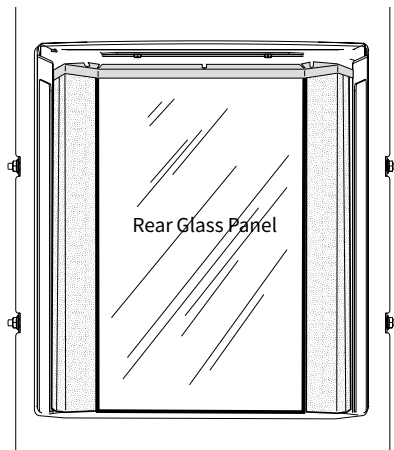

Figure 26. Install Rear Glass Panel.

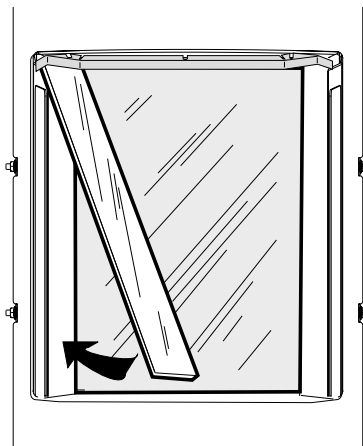

Figure 26a. Install Side Glass Panels.

8. Install Burner Media

River Rocks

CAUTION: THE ROCKS ARE FRAGILE! SUPPORT THE ASSEMBLY FROM THE BOTTOM AND HANDLE CAREFULLY!

1. Engage the River Rock bed with the two center burner pins as shown in fig. 27. Either side of the rocks may face outward as desired.
2. Evenly disperse the Ember Stones supplied over the burner plate around the log parts. **DO NOT ALLOW EMBER STONES TO BLOCK THE PILOT ASSEMBLY AREA.** The carry-over ports directly in front of the pilot must remain clear for proper pilot ignition. See figs. 29 and 65 for examples.

StarFire Glass Embers

Do not use more than the four pounds (in two, 2 lb. bags) of glass media provided. For best results, evenly spread the contents of the bag over the entire burner plate and rear skirt, mounding a crown toward the center.

DO NOT COVER THE AREA IMMEDIATELY IN FRONT OF THE PILOT ASSEMBLY. The carry-over ports directly in front of the pilot assembly must be clear to ensure proper pilot ignition. See fig. 66 page 34.

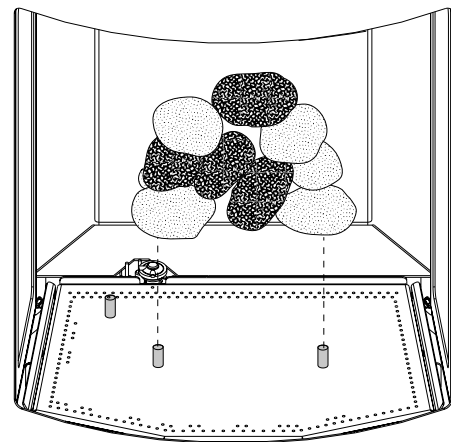

Figure 27. Set River Rock assembly on pins.

Tumbled Stones

Install the stones according to the instructions supplied with that kit.

Install the Log Set

The three-piece log set includes a bag of ember stones that simulate glowing coals when the burner is operating.

Use workgloves and handle the individual logs carefully, supporting each with both hands. Install the Logset and Ember Stones as shown in figures 28-31.

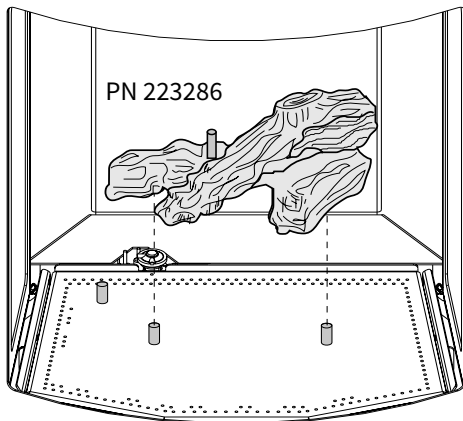

Figure 28. Engage the Center Log with the two center pins in the burner plate.

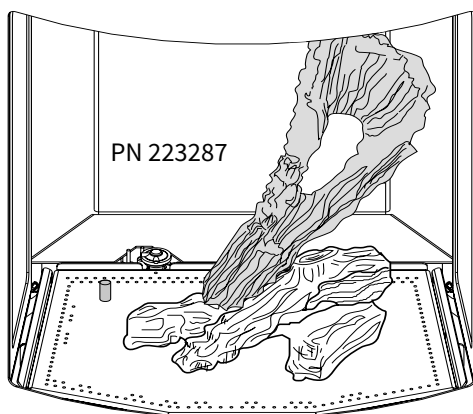

Figure 29. Lean the Right Log up against the upper right corner of the firebox and engage the slot on the tip with the pin on the Bottom Log.

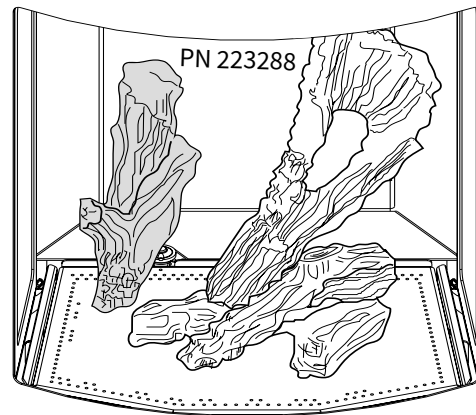

Figure 30. Engage the narrow end of the Left Log with the rear burner plate pin and lean it against the back wall.

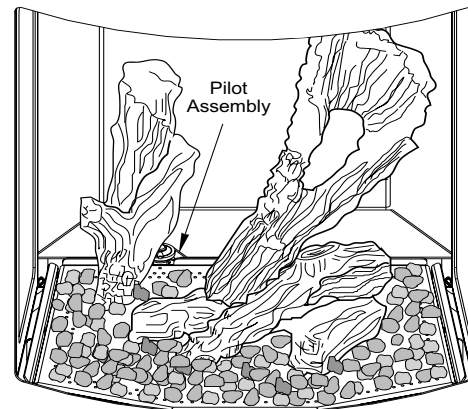

Figure 31.

Evenly disperse the Ember Stones over the burner plate around the log parts. **DO NOT ALLOW EMBER STONES TO BLOCK THE PILOT ASSEMBLY AREA.** The carry-over ports directly in front of the pilot must remain clear for proper pilot ignition.

Replace the Glass Frame

NEVER USE A POWER TOOL TO TIGHTEN GLASS FRAME HARDWARE. Use the 4 mm hex key provided to secure screws. Wear clean cut resistant gloves when handling the glass and glass frame.

Use the following procedure to ensure correct glass frame replacement:

- 1) Use a clean cloth to wipe away any dust or finger prints from glass.
- 2) Hold the glass frame to firebox front with holes in alignment where socket head screws were removed.

Replace the Glass Frame Continued.

- 3) Replace the socket head screws into glass frame finger tight. Readjust screws to ensure glass frame alignment. Take care not to cross thread screws.
- 4) Tighten screws in the following sequence to avoid placing uneven pressure on the glass:
 - 1) Upper left
 - 2) Lower right
 - 3) Upper right
 - 4) Lower left

10. Initial System Check

The burner and fan control system consists of the following built-in or supplied components:

- 1) Remote Transmitter - 3, AAA batteries preinstalled
- 2) Remote Receiver - 4, AA backup batteries preinstalled
- 3) Fan Control Module - switched

All internal connections have been made at the factory. The remote controls are preprogrammed and the entire system tested.

NOTE: Check the build date on the shipping crate label. If it has been more than 6 months since the build date, be prepared to replace the Receiver and Transmitter batteries.

Follow this procedure for the initial system check following installation:

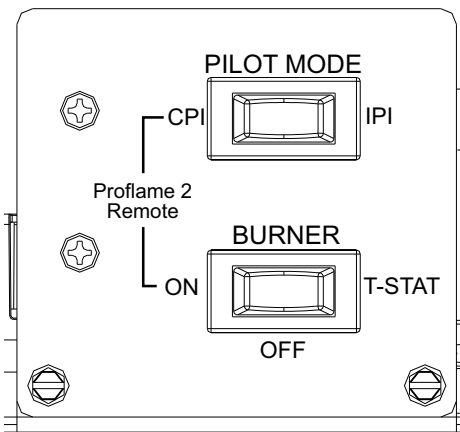

Figure 32. Rocker Switch

1. **Connect the power extension cord** to the interior power cord and to a 120V electrical outlet.
2. **PURGING THE GAS LINE:** Open the gas supply valve. When lighting the appliance for the first time it will take a few moments to clear the gas line of air. Once the purge is complete, the pilot light will be able to ignite.
3. **Set the Pilot Mode:**
 - CPI for continuous pilot operation or Proflame 2 Remote functionality.
 - IPI for intermittent operation.
4. Once the pilot is lit, burner operation is controlled by the rocker switch located on the front panel. See fig. 32.

ON / OFF - use for manual control of the burner. It remains in the ON position for use with the Proflame 2 remote transmitter.

T-STAT - use for optional wall thermostat.
5. **PILOT FLAME:** The pilot flame should be steady -not lifting or floating. The flame should be blue in color around the pilot hood, with traces of yellow toward the outer edges. It is important that the pilot flame engulf the top 1/8" of the flame sensor. The pilot flame should project out of the pilot hood 1" from both ports extending to reach the burner plate ports. See fig. 33. The pilot flame can be tuned by turning the adjustment screw located on the front of the valve. See fig. 20.
6. **INSTALLER PLEASE NOTE:**

CHECK FUNCTIONALITY. The burner, remote control and fan functions have each been tested at the factory. However, it is important to run through each function and be sure to familiarize the homeowner with the operation procedures. See the Operation section on pages 24-27 for details regarding Remote Control functions and settings.

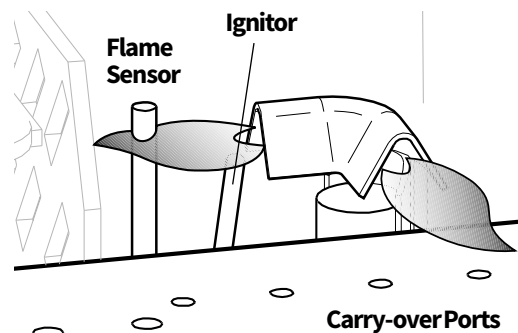

Figure 33. Correct Pilot flame pattern.

Flame Appearance / Air Shutter Adjustment

WARNING:
AIR SHUTTER ADJUSTMENTS SHOULD ONLY BE PERFORMED BY A QUALIFIED, PROFESSIONAL SERVICE TECHNICIAN.

Locate the Primary Air Shutter control under the firebox floor above the gas valve. See fig. 37. The shutter is set at the midpoint of its adjustment range at the factory. This will give good results in the majority of installation configurations, however, you may need find it necessary to adjust it to get the best flame picture depending upon the your specific installation.

With the burner operating, loosen the wingnut on the shutter stem. Push the stem back toward the rear of the stove will decrease combustion air. Pull it forward to increase air.

Generally, flame appearance is a matter of individual preference, however a warm yellowish flame is most common.

■ Closing the air shutter - in extreme cases may generate very long yellow flames resulting in soot. Sooting produces black deposits on the logs, on the inside walls of the appliance, and potentially on the exterior termination cap.

Sooting is caused by incomplete combustion in the flames and lack of combustion air entering the air shutter opening.

■ Opening the air shutter - will generate a flame that is blue and transparent, or “anemic”. This flame is generally more efficient, but not as attractive.

■ Allow the burner to operate at the highest setting for 20-30 minutes before making any adjustments. Always make adjustments in 1/8” increments and allow the burner to settle in for 10- 15 minutes between additional adjustments.

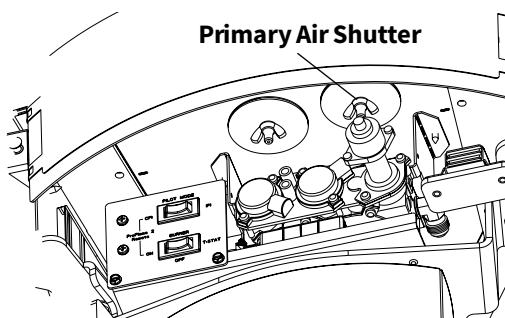

Figure 37. Air Shutter location.

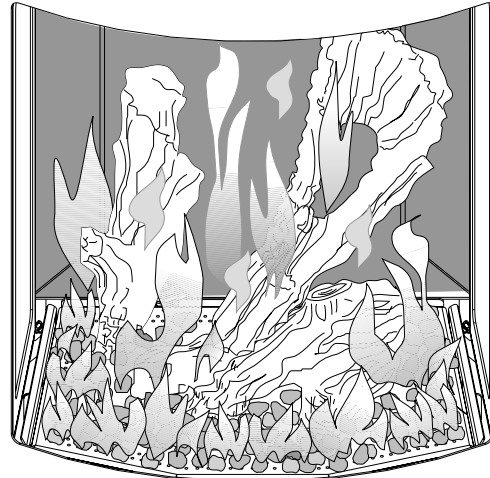

Figure 38. Proper flame picture -Traditional Logs.

Alternate flame pictures for Wishing Rock and Starfire Glass are illustrated in figs. 64 and 65 in the Appendix on page 30.

Operation Notes

1. For the first several hours of operation, it is common to detect some odor as the metal and manufacturing materials cure under heat. This condition is temporary and can be alleviated by allowing plenty of fresh air to circulate through the area.
2. Condensation may develop on the glass upon each lighting of the appliance. This “fog” will disappear as the glass heats.
3. Keep the controls and the area under the appliance free of dust. Always keep the appliance area clear and free from combustible materials, gasoline and other flammable liquids.
4. This appliance can be operated with a continuously burning pilot flame. Exercise caution when using household products containing combustible vapors.
5. **CAUTION: DO NOT OPERATE THIS APPLIANCE WITH THE GLASS REMOVED, CRACKED OR BROKEN. REPLACEMENT OF THE GLASS SHOULD BE DONE BY A LICENSED OR QUALIFIED SERVICE PERSON. USE ONLY REPLACEMENT GLASS PROVIDED BY YOUR AUTHORIZED JØTUL DEALER. NEVER USE ANY SUBSTITUTE MATERIALS.**

Proflame 2 Remote Control

Features Overview

The Proflame 2 Integrated Fireplace Control (IFC) incorporates electronic remote control of the Jøtul GF 370 DV II IPI features. It is configured to control the on/off operation both manually and thermostatically, with standard and “Smart” thermostat features. It will also control flame modulation, fan power and speed, accent lighting function and level.

The system utilizes an IPI system (Intermittent Pilot Ignition) and may also be switched to keep the pilot lit continuously for up to seven (7) days if desired (CPI - Continuous Pilot Ignition). After 7 days, the unit will automatically switch to IPI mode and ignite the pilot only when there is a call for heat.

Power is provided to the IFC by 120V house current and is backed-up by a 6V battery pack (4, AAA) for operation during a power failure.

Remote Control Transmitter

The remote transmitter has all controls available on its face for reliable, ease of use. It gives room temperature readout, set temperature readout, all function abilities as well as childproof lockout and low battery indicator. Icons appear on the screen indicating which mode of operation you are controlling. The four button controls are easy to learn and simple to operate. The transmitter is powered by 3, 1.5V AAA batteries.

Remote Control Receiver

The receiver is integrated with the IFC board which is located within the valve compartment.

Integrated Fireplace Control (IFC)

The IFC is the electrical heart of the system. It provides power to all components and converts to 6.5v DC in the event of power failure. The IFC sends power to the fan system and the accent light. When no line power is available these features will not operate, however the battery back-up allows remote control of burner operation.

Sit 885 Modulating Valve

This valve has the ability to be stepped down in six increments between high and low. It can be done manually or by setting the remote control to the Smart thermostat modulation mode. Automatic modulation means that as the room temperature approaches the limit set for shut down, the valve gradually decreases or “steps-down” the

fire intensity. Conversely, as room temperature cools, the valve gradually increases flame intensity. The overall result is more comfortable, even heating that minimizes temperature peaks and valleys.

Pilot Assembly

The pilot contains a pilot hood, igniter, and a flame sensor. The igniter sends a spark to the pilot hood which lights the gas. The sensor is then engulfed by the pilot flame, flame rectification occurs and the unit remains lit. If rectification does not occur, the main burner will not light, and the pilot will shut down.

WARNING:

READ AND UNDERSTAND ALL OPERATING INSTRUCTIONS BEFORE ATTEMPTING TO OPERATE THIS APPLIANCE. DO NOT ALLOW ANYONE TO OPERATE THIS APPLIANCE WHO HAS NOT READ AND UNDERSTOOD THESE INSTRUCTIONS. KEEP THE REMOTE CONTROL TRANSMITTER WHERE CHILDREN CANNOT REACH IT.

WARNING:

SEVERE INJURY. THIS APPLIANCE CAN BE SET TO OPERATE THERMOSTATICALLY. BE AWARE THAT THE FIREPLACE MAY BE VERY HOT EVEN WHEN THE BURNER IS NOT APPARENTLY OPERATING. KEEP CHILDREN AWAY FROM THE APPLIANCE.

WARNING:

FIRE HAZARD. CAN CAUSE SEVERE INJURY OR DEATH. THE APPLIANCE CAN TURN ON SUDDENLY. KEEP AWAY FROM THE APPLIANCE BURNER WHEN OPERATING THE REMOTE SYSTEM.

WARNING:

OBSERVE CAUTION NEAR THE GLASS PANEL. THE GLASS MAY SHATTER IF STRUCK BY AN OBJECT ALWAYS HANDLE THE GLASS PANEL WITH CARE.

ATTENTION:

- **TURN “OFF” MAIN GAS SUPPLY PRIOR TO REMOVING OR REPLACING BATTERIES.**
- **IN CASE OF REMOTE CONTROL MALFUNCTION, TURN OFF THE IFC DEVICE USING THE MAIN “ON/OFF” SWITCH.**
- **FOR INSTALLATION/MAINTENANCE SWITCH “OFF” THE IFC DEVICE BY DISCONNECTING THE MAIN POWER SUPPLY PLUG.**

Control Functions

Pilot Mode

Set the stove switch to CPI mode for Proflame 2 remote control. The IPI/CPI functionality will be controlled by the remote transmitter.

Burner Control

Set the stove burner switch to ON for Proflame 2 remote control.

OFF - Turns off both remote and manual burner functionality. Switch to OFF when the stove will not be used for an extended period of time.

Remote Transmitter

The Transmitter features a simple button layout and informative display screen. See figs. 51-52.

LCD DISPLAY - graphically indicates temperature settings and status of the Thermostat, Burner, Fan, and Accent Lamp.

ON / OFF Key - controls Burner, Fan, and Lamp functions.

THERMOSTAT Key - Used to set either Manual or Thermostatic Control and index through thermostatic functions.

UP / DOWN Arrow Key - Selects thermostat temperature range, fan speed, and flame height.

MODE Key - used to select the component to be controlled: CPI/IPI, Burner, Fan, and Accent Lamp.

The Wall Mount Bracket can be used for convenient Transmitter storage.

Initializing the System

1. Grasp the bottom of the Front Panel and swing it open to the left. Switch the Burner to OFF.
2. Install three AAA batteries into the hand-held Transmitter.
3. Press the black (or red) button on the left front corner of the IFC board, next to the controls switch plate. The board will “beep” three times and a yellow LED indicates a 10-second synchronization time limit.
4. Within the 10-second time frame, push the ON button on the Transmitter. The IFC will “beep” four times to indicate that it has acknowledged the transmitter command and sets to the particular code of that Transmitter.
5. After initialization, the burner switch must be placed in the ON position and Pilot Mode switch placed in CPI. The remote can then be used to control the burner.

To return to full Manual functionality, hold the red or black initialization button down until it “beeps” three or four times and the yellow LED illuminates. Within 10 seconds, push the button again until it signals the acknowledgement.

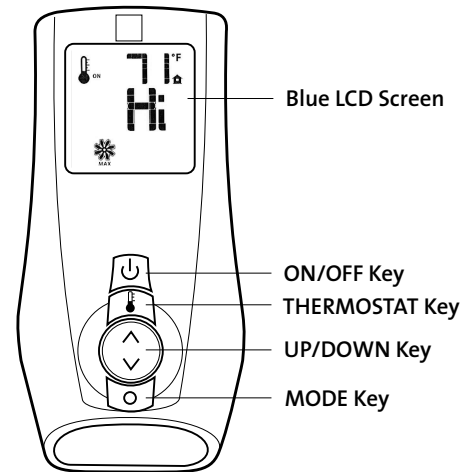

Figure 40. Remote transmitter function keys.

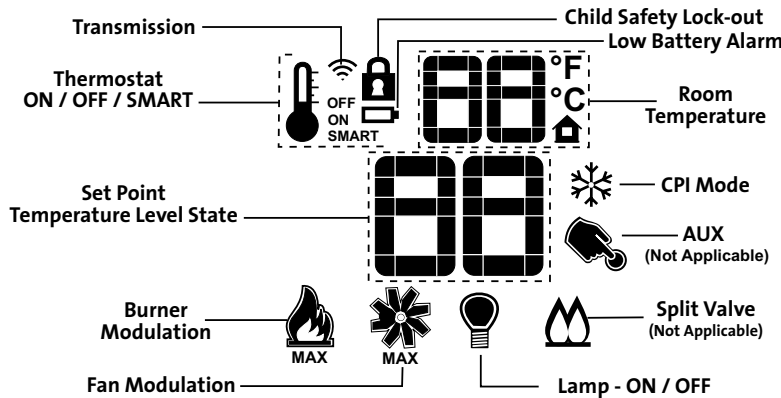

Figure 41. Remote transmitter display data.

Remote Transmitter Controls, cont'd.

Temperature Indication Display

- With the transmitter in the OFF position, press the Thermostat Key and the Mode Key at the same time. The display screen will show the current room temperature cycling between Fahrenheit and Celsius indicators each time the keys are pressed simultaneously. See fig. 42.

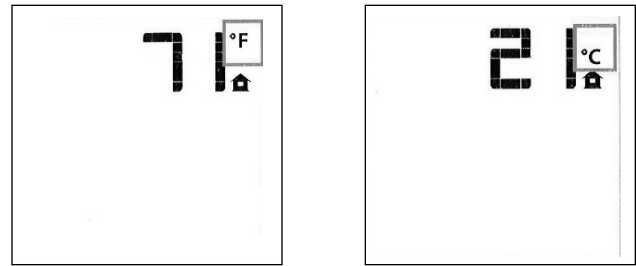

Figure 42. Room temperature readings

Turn on the Burner

- Press the ON/OFF Key on the Transmitter. The display will show all the active icons. At the same time, the Receiver will activate the Pilot Ignitor. First the pilot will ignite, followed shortly by the burner. A single "beep" from the Receiver will confirm reception of the command.

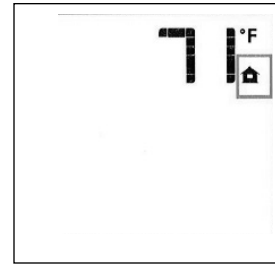

Figure 43. Burner shut-down

Turn off the Burner

- Press the ON/OFF Key. The display will show only the room temperature and icon. At the same time, the Receiver will deactivate the call for heat and the burner will shut down. Fig. 43. A single "beep" from the Receiver will confirm reception of the command.

Remote Burner Control

There are six flame levels available.

- With the system ON, and the burner flame level at maximum, press the Down Arrow Key once to reduce the flame height by one step. Each time the Down Key is pressed, the flame will step down until the burner is finally turned off. Fig. 44.
- The Up Arrow Key will increase the flame height each time it is pressed. If the U Arrow Key is pressed while the system is on but the flame is off, the flame will come on in the High position. Figs. 45-47. A single "beep" will confirm reception of the command.



Figure 44. Burner OFF.

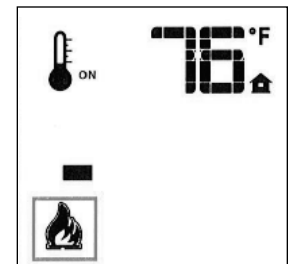

Figure 45. Flame Level 1.

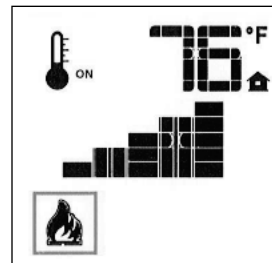

Figure 46. Flame Level 5.

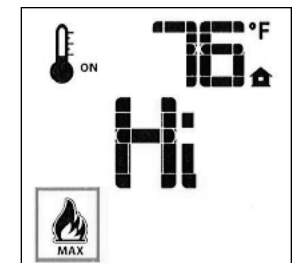

Figure 47. Flame Level 6.

Room Thermostat (Transmitter Operation)

The Remote Control can operate as a room thermostat. The thermostat can be set to a desired temperature to control the comfort level in a room.

- To activate this function, press the Thermostat Key, (Fig. 40.) The display will indicate that the room thermostat is "ON" and the current Set Temperature is now displayed. Fig. 48.
- To adjust the Set Temperature, press the Up or Down Arrow Keys until the desired Set Temperature is displayed. Fig. 49.

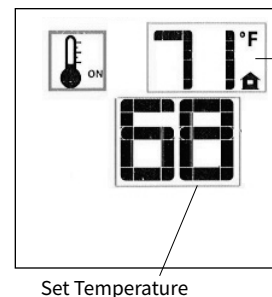

Figure 48. Thermostat ON

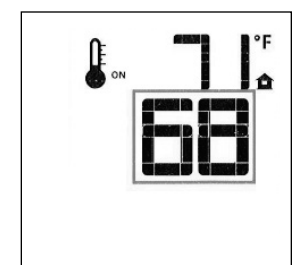

Figure 49. Change Set Temperature

SMART Thermostat Function

This function adjusts the flame intensity according to the difference in the Set Point temperature and the actual room temperature. As the room temperature gets closer to the Set Point, the Smart Function will modulate flame intensity down.

- To activate this function, press the Thermostat Key until the word “SMART” appears to the right of the thermometer bulb icon. Fig. 50.
- To adjust the temperature, press the Up or Down Arrow Keys until the desired Set Temperature is displayed. Fig. 51.

Fan Speed Control

- Fan speed can be adjusted through six settings. To activate this function, press the Mode Key (Fig. 40) to index to the Fan Control icon. See fig. 52.
- Use the Up/Down Arrow Keys to turn ON, OFF, or adjust the fan speed. Fig. 53. A single “beep” will confirm reception of the command.

Accent Lamp Control (Auxiliary 120V Outlet)

- The auxiliary function controls the Accent Lamp power. Press the Mode Key to index to the AUX icon. Figs. 54-55.
- Pressing the Up Arrow Key will turn the Lamp ON. Lamp brightness can be adjusted by turning the dimmer knob on the stove Control Panel.
- Pressing the Down Arrow Key will turn the Lamp OFF.

Child Safety Lock

This function will lockout the Transmitter to prevent unsupervised operation.

- To activate the Lock, press the Mode key and UP Key at the same time. Fig. 56.
- To de-activate the Lock, press the Mode Key and UP Key at the same time.

Low Battery Detection

The life-span of the batteries depends on various factors; battery quality, the frequency of ignition calls, the frequency of changes to Set Points, etc.

- When Transmitter batteries are low, the Battery icon will be displayed before all battery power is lost. The icon will disappear when new batteries are installed.
- When Receiver batteries are low, no “beep” will be emitted from the Receiver when it receives an On/Off command from the Transmitter. This is an alert for a low battery condition in the Receiver. When the batteries are replaced, the “beep” will be emitted from

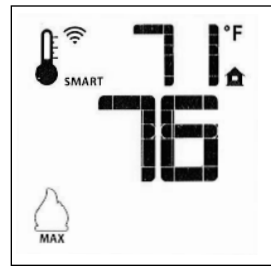

Figure 50. Smart Mode

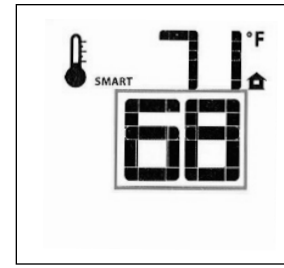

Figure 51. Smart Set Temp.

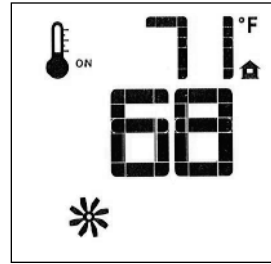

Figure 52. Fan Mode

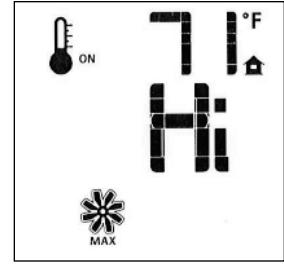

Figure 53. Fan Speed



Figure 54. Lamp Control

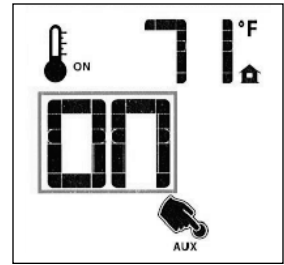

Figure 55.. Lamp ON

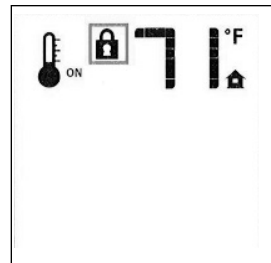

Figure 56. Lock ON

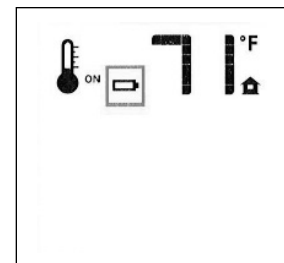

Figure 57. Low Battery

the Receiver when the ON/OFF Key is pressed. See Battery Replacement under the Maintenance section of this manual.

Manual By-Pass of the Remote System

When battery power is low or depleted, the burner can still be operated manually by sliding the Receiver switch to the ON position. It will immediately ignite in the High position.

In the event of a power failure, flame modulation, thermostatic control, fan and lamp functions will be unavailable. It is therefore advisable to keep a supply of good quality batteries on hand.

Maintenance

This appliance and its venting system should be inspected before use and at least annually by a qualified service technician.

WARNING!
THE IGNITION SYSTEM OF THIS APPLIANCE CARRIES LIVE VOLTAGE. ALWAYS SHUT “OFF” THE MAIN GAS SUPPLY AND DISCONNECT THE POWER SOURCE BEFORE PERFORMING ANY MAINTENANCE PROCEDURE.

TURN “OFF” THE MAIN GAS SUPPLY AND DISCONNECT THE POWER SUPPLY TO THE APPLIANCE BEFORE REPLACING BATTERIES.

Annual Cleaning

Vent System

The entire vent system should be inspected and cleaned every year. If the intake and exhaust venting is disassembled for any reason, it should be reassembled and sealed according to the vent manufacturer’s instructions provided at the initial installation.

Burner and Log Set

Periodically inspect the firebox and valve compartment to BE CERTAIN THAT THE FLOW OF COMBUSTION AND VENTILATION AIR IS UNOBSTRUCTED. INSPECT THE PILOT ASSEMBLY FOR CORROSION AND REPLACE ANY AFFECTED PARTS.

The firebox should be vacuumed at least annually to remove any surface build up. Use a soft brush attachment and handle the logs carefully as they are fragile.

Glass Care

Clean the glass as necessary. Wipe the surface with a clean, dampened, soft cloth. Follow with a dry, soft towel. Take care not to scratch the glass surface.

WARNING: DO NOT USE ABRASIVE CLEANERS ON THE GLASS. NEVER CLEAN THE GLASS WHEN IT IS HOT.

Gasket Inspection

It is important that the glass gasket be inspected at least annually. Examine the ribbon gasket for signs of deterioration and make sure the gasket has a positive seal. Replace the gasket if necessary.

NOTE: INSPECT THE GLASS SURFACE FOR SCRATCHES AS THESE CAN WEAKEN THE PANEL TENSILE STRENGTH. REPLACE THE PANEL IF ANY SCRATCHES ARE FOUND. USE ONLY JØTUL CERAMIC GLASS PANELS: 156835 SIDE AND 156833 FRONT.

Glass Panel or Gasket Replacement

1. Use the 4 mm hex key to remove the four socket screws that attach the Glass Frame to the firebox.
Remove the lower screws first and be sure to adequately support the frame against the firebox while you remove the upper screws.
2. Lay the assembly upside down on a flat surface, protecting the frame from scratches using a blanket or towel.
3. The glass panel is held in place by four retainer tabs. Use a screwdriver to carefully pry these up off the edge of the glass retaining walls. If the tabs break off, use the Tinnerman clips supplied with the replacement glass kit to secure the glass panel within the frame.
4. Remove the old gasket material.
5. Beginning at the midpoint of the upper edge, apply the new gasket around the glass panel, with the adhesive side inside and the thicker portion on the outside. **DO NOT STRETCH THE GASKET MATERIAL.** Trim off any excess, leaving a 1/2” overlap as shown in fig. 58.
6. Lay the glass panel within the glass frame and press the tabs back down or press the clips in place as shown in fig. 59.

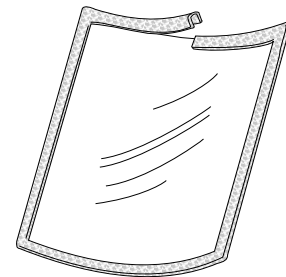
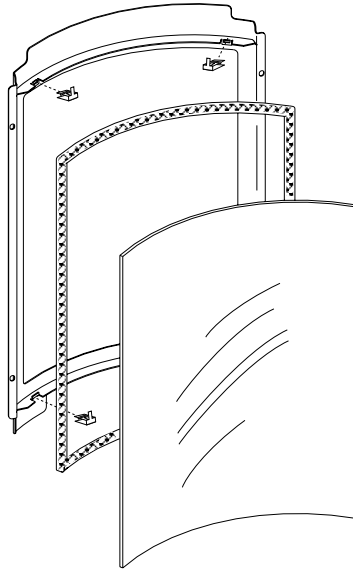

Figure 58.
Gasket application,
PN 129124

StarFire Glass Embers

NOTE: Glass embers may discolor over time, depending upon frequency of use. Clean the embers by washing in warm, soapy water, and dry thoroughly before reinstallation and use. After washing, discard any permanently hazed pieces, or replace embers annually. Colored glass embers, not supplied by Jøtul, maybe used, but must be at least 1/2” and similar in size and shape.

Figure 59.
156833
Front Glass
Replacement
Kit includes
gasket and spare
retainer clips.



Battery Replacement

Battery life depends on many variables; the quality of the batteries, frequency of remote use, and mode of pilot operation. Keep a supply of good quality batteries on hand to be assured of functional continuity in the event of a power failure.

WARNING!

ALWAYS SHUT OFF THE GAS SUPPLY AND DISCONNECT THE POWER CORD FROM HOUSE CURRENT BEFORE REPLACING BATTERIES.

IFC Battery Replacement

A red LED on the IFC board indicates low battery power.

1. Switch the Burner to OFF and disconnect power to the stove.
2. Access the battery box from the left side of the control compartment. It is directly behind the control switch plate. See fig. 68, #27. Disengage the box from the hook & loop tape and pull it out of the compartment.
3. Slide the cover back, install four, 1.5v AA batteries and replace the box, tucking the wire leads within the compartment.
4. Reconnect power to the stove.
5. Re-initialize the Remote Control transmitter following the instructions below.

Initializing the Remote Control

Each time you replace the batteries, you will need to initialize communication between the Receiver and the Transmitter.

1. Place the slider switch in the REMOTE position.
2. Insert the end of a paper clip into the hole marked PRG on the Receiver cover. The Receiver will “beep” three (3) times to indicate that it is ready to synchronize with the Transmitter.
3. Install 3 AAA batteries in the Transmitter bay and push the ON button. The Receiver will “beep” four times to indicate the Transmitter’s command is accepted and sets to the particular code of that Transmitter. The system is now initialized.

Accent Lamp Replacement

Handle the replacement bulb with gloves. Skin oils will cause the bulb to fail prematurely.

1. Remove the glass frame. See fig. 18.
2. Remove the two retainer screws with a short phillips screwdriver. Pull the socket out of the housing.
3. Plug the new bulb into the socket and re-install the assembly into the lamp housing.
4. Replace the glass frame using the 4 mm hex key and socket head screws previously removed.

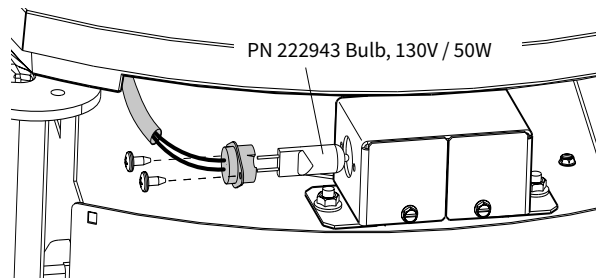

Figure 60. Accent Lamp Replacement.

Proflame 2 IFC Wiring Diagram

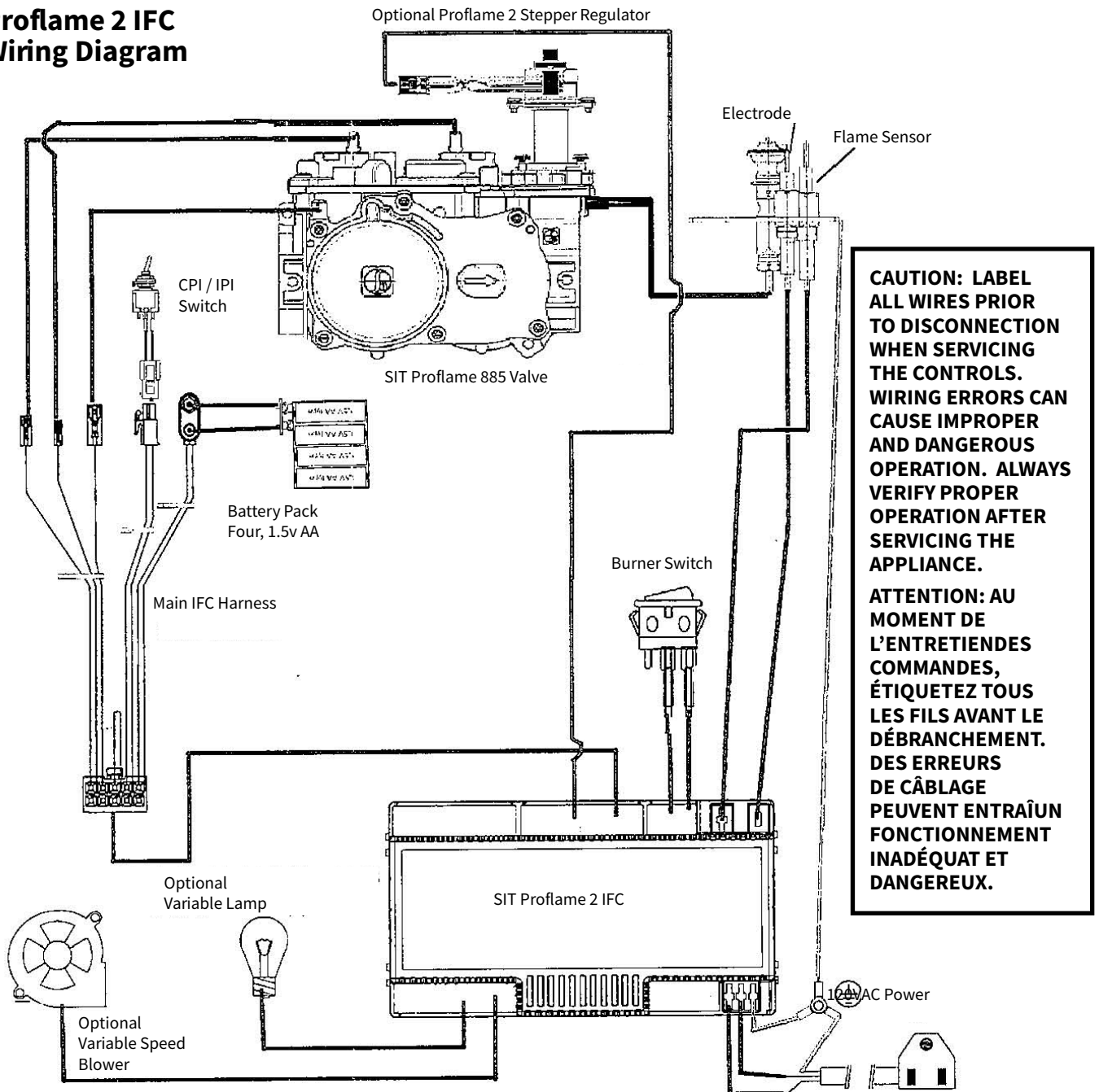

Figure 61. GF 370 DV II IPI with Proflame 2 Premium Remote Control Accessories

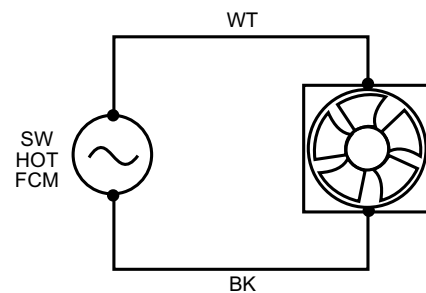

Figure 62. Wiring Diagram - GF 370 DV II IPI Fan

Appendix

1. Top Plate Shims

1. Remove the Top Plate.
2. Remove the three shims highlighted in the illustration below.
3. **Matte Black Stoves:** Replace the Top Plate and discard the shims.

Linen Enamel Stoves: Locate the three shims shipped separately within the firebox and install these in the same locations as those previously removed.

Replace the Top Plate.

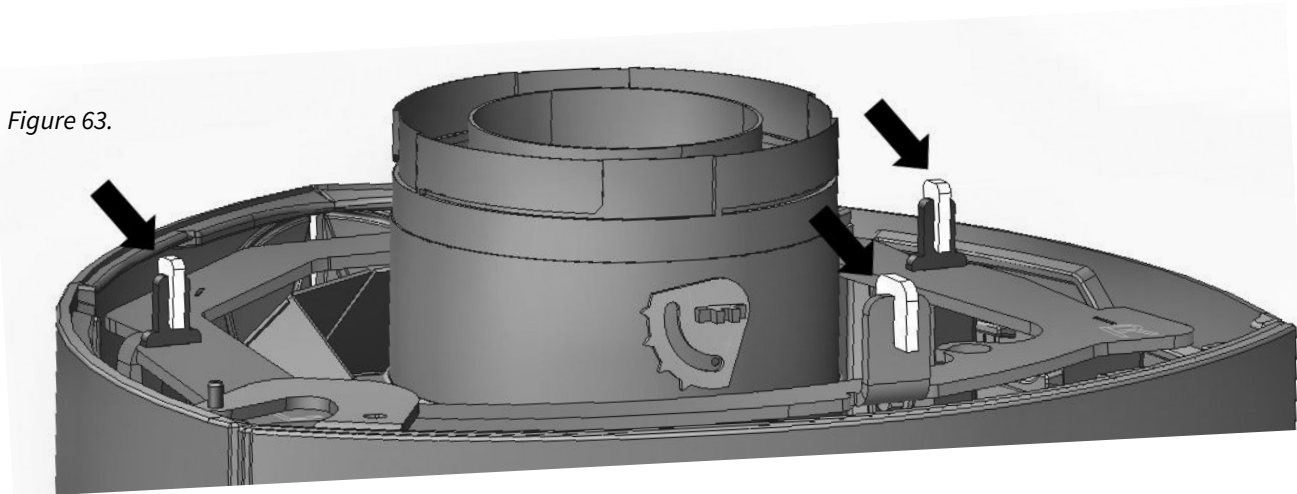

2. Correct Flame Pictures

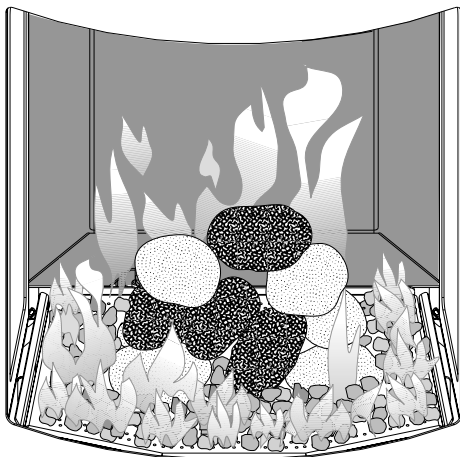

Figure 64. River Rock flame picture. KEEP EMBER STONES OFF PILOT CARRY-OVER PORTS.



Figure 65. Starfire Glass flame picture.

3. Mobile Home Installation

The Jøtul GF 370 DV II IPI can be installed for use in a mobile home in the U.S. and Canada provided:

1. The stove must be secured to the floor of the mobile home. There is a hole for this purpose, located in the pedestal base, through which a lag screw or other appropriate fastener should be secured to the floor. See Fig. 1, page 3.
2. The stove is installed in accordance with Title 24 CFR, Part 3280- Manufactured Home Construction and Safety Standard, in the U.S. Comply with CSA Z240.4, Gas Equipped Recreational Vehicles and Mobile Housing, in Canada.
3. Always contact your local officials about installation restrictions and requirements in your area.

THIS APPLIANCE MAY BE INSTALLED AS AN OEM INSTALLATION IN A MANUFACTURED (MOBILE) HOME AND MUST BE INSTALLED IN ACCORDANCE WITH THE MANUFACTURER'S INSTRUCTIONS AND THE MANUFACTURED HOME CONSTRUCTION AND SAFETY STANDARD, TITLE 24 CFR, PART 3280, STANDARD FOR MANUFACTURED HOME INSTALLATION, ANSI/NCBCS A255.1 OR STANDARD FOR CANADA, CSA Z240.4. THIS APPLIANCE IS ONLY FOR USE WITH THE TYPE OF GAS THAT IS INDICATED ON THE STOVE'S RATING PLATE. THIS APPLIANCE MAY BE INSTALLED IN AN AFTERMARKET PERMANENTLY LOCATED, MANUFACTURED (MOBILE) HOME, WHERE NOT PROHIBITED BY LOCAL CODE.

CET APPAREIL PEUT ETRE INSTALLE DANS UN MAISON PREFABRIQUEE (MOBILE) DEJA INSTALLEE A DEMEURE SI LES REGLEMENTS LOCAUX LE PERMETTENT.

CET APPAREIL DOIT ETRE UTILISE UNIQUEMENT AVEC LES TYPES DE GAS INDIQUES SUR LA PLAQUE SIGNALÉTIQUE. NE PAS L'UTILISER AVEC D'AUTRES GAS SAUF SI UN KIT DE CONVERSION CERTIFIE EST INSTALLE.

4. Beachfire Logset

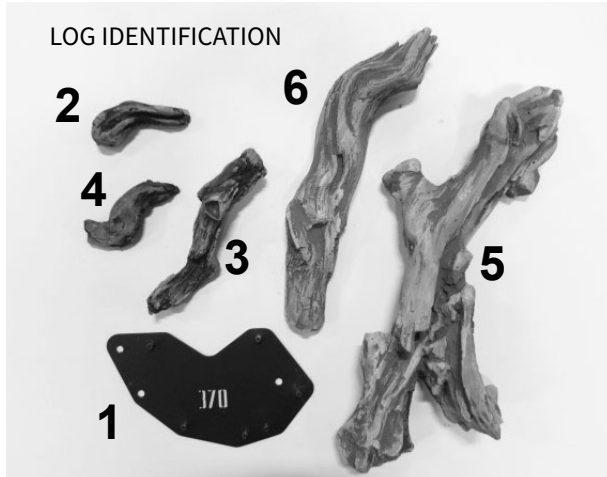

- 1. Log Retainer 22664192
- 2. Left Rear Log 226843
- 3. Center Burner Log 226849
- 4. Right Front Log 226845
- 5. Left Vertical Log 226850
- 6. Right Vertical Log 226851

1. Refer to the Contents list and lay out the logs to identify the parts as shown. The logs engage with steel pins on the Adaptor Plate (1). Identify pin engagement holes in the underside of logs 2, 3, and 4. Engagement holes are in the lower ends of logs 5 and 6.

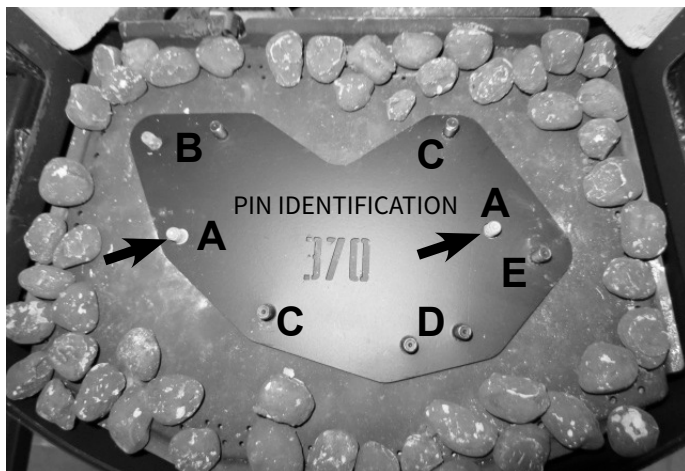

- 2. Install the Adaptor Plate (#1) on the burner by engaging it with the two burner pins (A) at the arrows shown above.
- 3. Loosely spread a layer of ember stones around the perimeter of the burner plate.

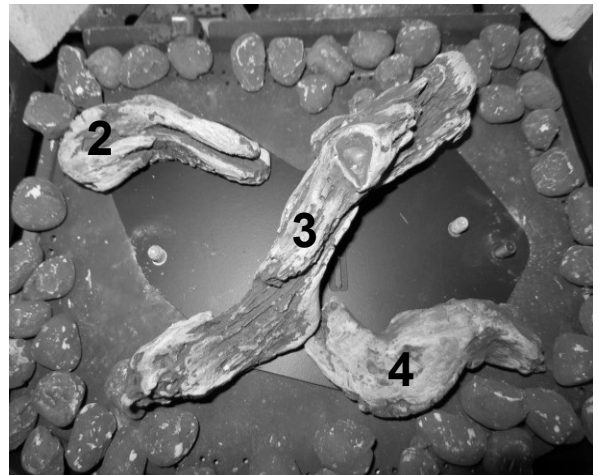

- 4. Engage the holes in the bottom of Rear Log (#2) with the two steel pins (B) at the left rear corner of the burner plate.
- 5. Engage the two holes in the bottom of the Center Log (#3) with the two burner plate pins (C).
- 6. Engage the holes in the Front Log (#4) with the two pins (D) in the right front corner.



- 7. Engage the hole at the lower end of the Left Vertical log (#5) with left Adaptor pin "A". See Step 2 photo.

Rest the right fork of the log upon the Center log and lean the upper end against the rear wall of the firebox as shown.

Replace the Glass Frame

NEVER USE A POWER TOOL TO TIGHTEN GLASS FRAME HARDWARE. Use the 4 mm hex key provided to secure screws. Wear clean cut resistant gloves when handling the glass and glass frame.

Use the following procedure to ensure correct glass frame replacement:

- 1) Use a clean cloth to wipe away any dust or finger prints from glass. Do NOT use ammonia based glass cleaner.
- 2) Hold the glass frame to firebox front with holes in alignment where socket head screws were removed.
- 3) Replace the socket head screws into glass frame finger tight. Readjust screws to ensure glass frame alignment. Take care not to cross thread screws.
- 4) Tighten screws in the following sequence to avoid placing uneven pressure on the glass:
 - 1) Upper left
 - 2) Lower right
 - 3) Upper right
 - 4) Lower left



8. Engage the hole at the lower end of the Right Vertical log (#6) with pin "E" on the Adaptor plate.

Rest the upper end against the depression on the log #5 as shown.

Illustrated Part Breakdown

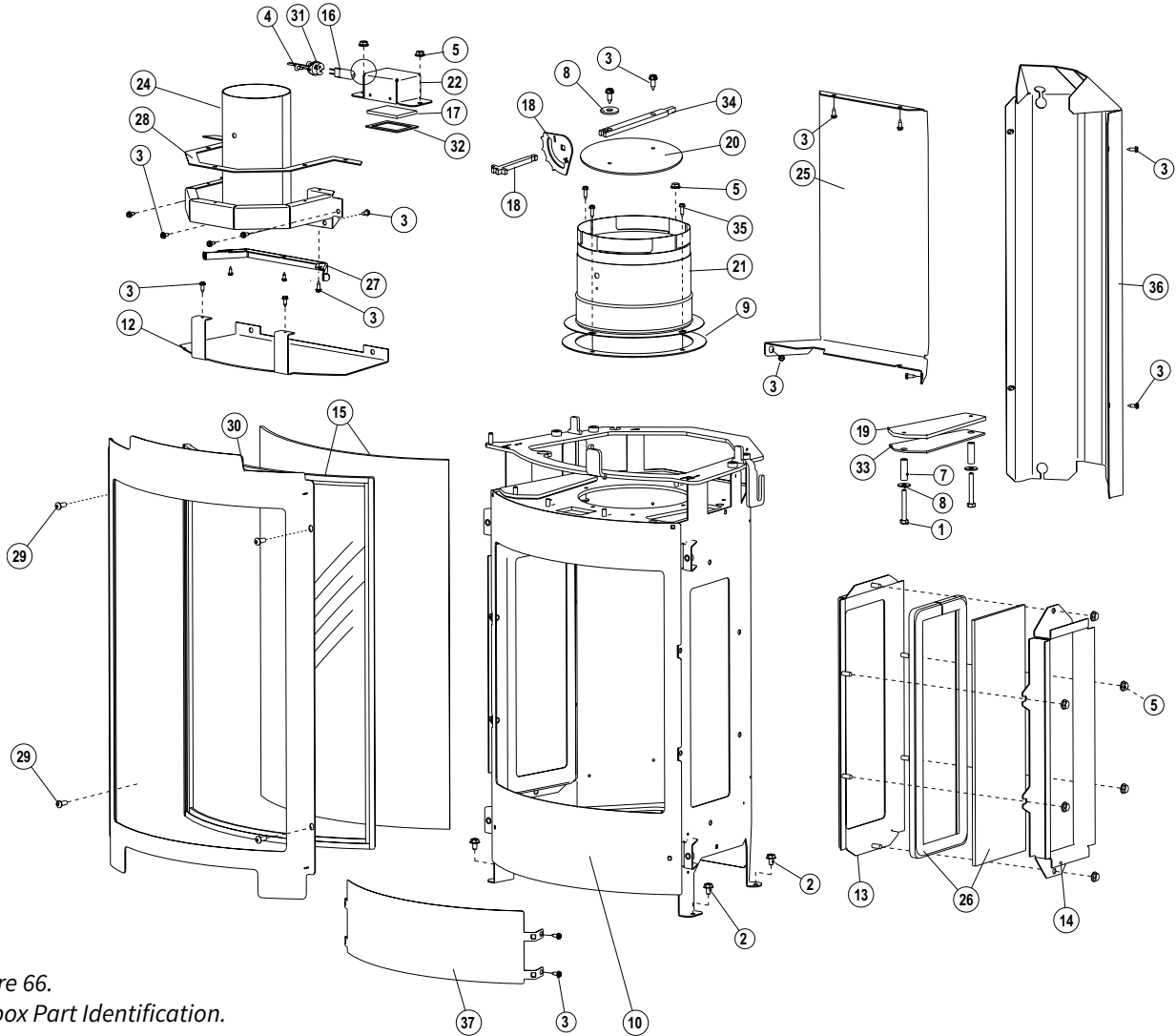
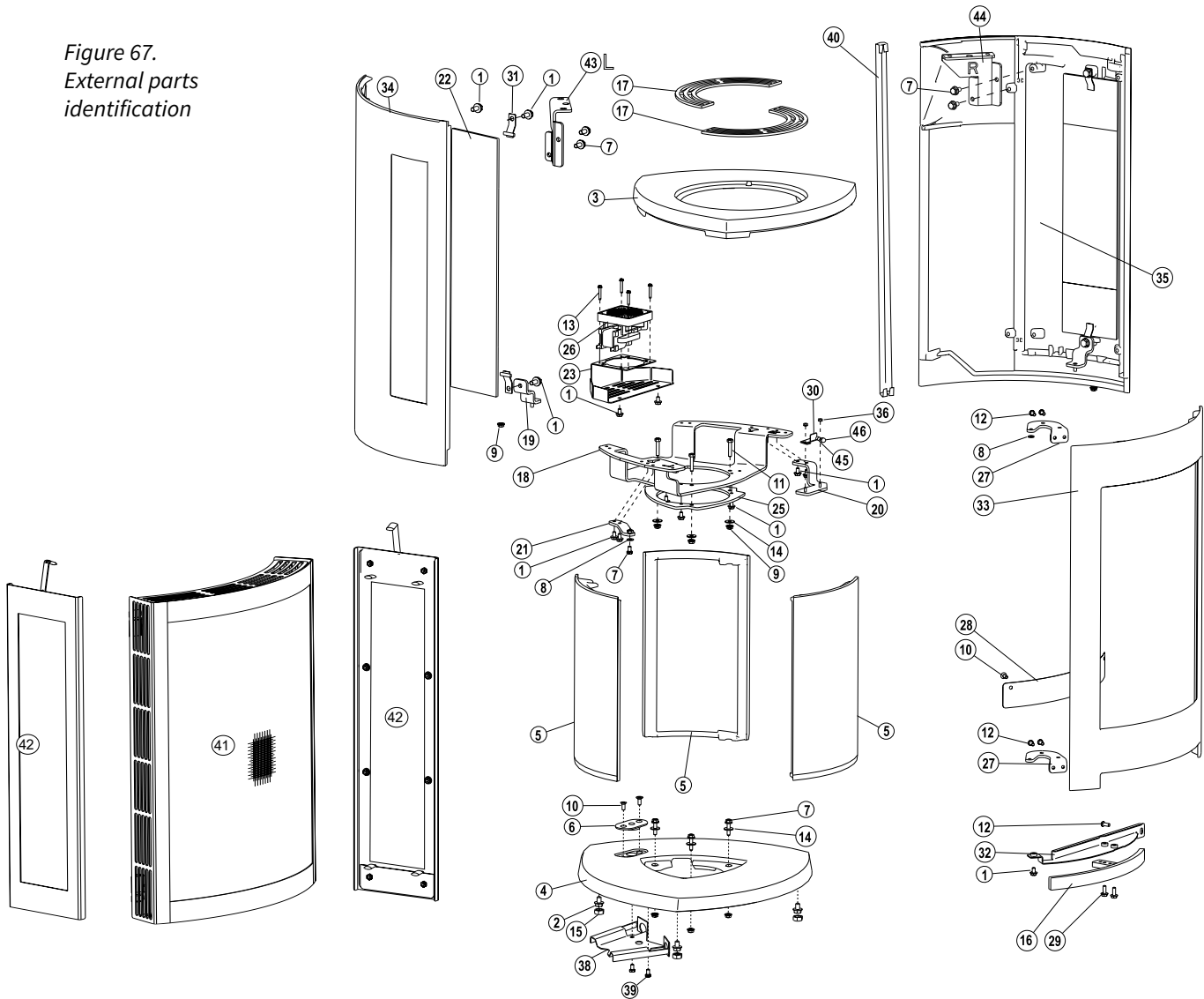

Figure 66.
Firebox Part Identification.

No.	Part Number	Description	No.	Part Number	Description
1	9911	Bolt, Hex Cap, M6x45, DIN 933, Class 8.8, Blk	21	22298392	Simpson DV II Starter Collar, GF 370, MB
2	9962	Bolt, Hex Cap M6x10 DIN 933 8.8 Ser Flange Blk	22	22298892	Light Box, Inner
3	117917	Screw, HWH SMA 8 x 1/2 SL Blk Oxide	24	223202	Intake Manifold, GF 370
4	117967	Screw, Pan Head #7 x 3/8 PH SMA Zinc	25	22320592	Burner Skirt, Rear, GF 370, MB
5	117968	Nut, M6 Serrated Flange plain	26	156834	Replacement Inner Side Glass & Gasket, GF 370
6	117978	Screw, Button Head Socket M6X10 Blk	27	22324392	Panel Retainer, GF 370
7	118267	Spacer, .375 O.D. x 1.50	28	223295	Gasket, Intake Manifold, GF 370
8	120004	Washer, Fender M6 DIN 9021B Zinc	29	118201	Screw, Button Head Socket, M6 X 16, Blk
9	129118	Gasket, Starter	30	22259292	Glass Frame, Curved, GF 370, MB
10	222580	Firebox Weldment, GF 370	31	156824	Replacement Light Socket Ass'y, GF 370
12	22258892	Baffle, Firebox, GF 370, MB	32	222977	Gasket, Light Kit
13	22258992	Glass Frame, Side, Inner, GF 370, MB	33	222993	Gasket, Relief Door, GF 370
14	22273592	Glass Shade, Side, GF 370, MB	34	225403	Inner Rod, Exhaust Restrictor
15	156833	Replacement Front Glass & Gasket, GF 370	35	118090	Screw, HWH SMA 8 x 5/8 SL Zinc
16	222943	Light Bulb, 130 Volt, 50 Watt	36	22321992	Shroud, Rear, GF 370, MB
17	222974	Glass, Ceramic, Light Fixture, GF 370	37	22328292	Firebox Cover, GF 370, MB
18	22298092	Restrictor Indicator Washer	38	225402	Outer Rod, Exhaust Restrictor
19	222981	Delay Door, GF 370	39*	223224	Skamol, Rear Panel
			40*	223235	Skamol, Side Panel, 2

* not illustrated

Figure 67.
External parts
identification



No.	Part Number	Description
1	117874	Bolt, Hex Hd M8 x 16 Ser Flange, Blk
2	99115	Bolt, Hex Hd M8 x 12 Ser Flange, Blk
3	10447092	Top Plate, Matte Black Paint
	10447054	Top Plate, Linen Enamel
4	10431992	Pedestal Base, Matte Black Paint
	10431954	Pedestal Base, Linen Enamel
5	10448892	Pedestal Side, Matte Black Paint
	10448854	Pedestal Side, Linen Enamel
6	10453692	Access Cover, Matte Black Paint
	10453653	Access Cover, Linen Enamel
7	118019	Bolt, Hex Hd Serr Flange M6 x 25 Blk
8	117947	Washer, Flat M6 -.062 DIN 125A Plain
9	117968	Nut, M6 Serrated Flange plain
10	117976	Screw, Flat Head Phillips M6 x 12 M/S Blk
11	9906	Bolt, Hex Cap, M6x30, DIN 933, Class 8.8, Blk
12	117978	Screw, Button Head Socket M6 x 10 Blk
13	118095	Screw, HWH, SMA, #8 x 1", SL, Zinc
14	120004	Washer, Fender M6 DIN 9021B Zinc
15	222664	Protection Cap, M8 Hex, Black
16	222729	Door Handle, Plated, GF 370
17	22299592	Top Grill, GF 370, MB
18	222998	Bracket, Firebox Mount, GF 370
19	222999	Bracket, Side Support, GF 370
20	22320792	Bracket, Door Catch, GF 370, Matte Black
21	156843	Lower Door Hinge Asy. GF 370, MB
22	156835	Replacement Outer Side Glass, GF 370
23	22321692	Bracket, Blower Mount, GF 370, MB

No.	Part Number	Description
25	223220	Plate, Centering, GF 370
26	223227	Blower, Axial, 40 CFM, 120 V
27	22558492	Hinge, Door, MB
	22606992	Hinge, Door, for Enamel stove
28	223236	Label, Caution,
29	99625	Bolt, Hex Head Serr Flange M6x16 8.8 Blk
30	226632	Bracket, Magnetic Catch, GF 370/373
31	156837	Replacement Outer Side Glass Clip Ass'y.
32	22328592	Bracket, Handle, MB
33	10446392	Door, Matte Black Paint
	10446354	Door, Linen Enamel
34	10446492	Side Plate, Left, Matte Black Paint
	10446454	Side Plate, Left, Linen Enamel
35	10446592	Side Plate, Right, Matte Black Paint
	10446554	Side Plate, Right, Linen Enamel
36	118055	Kepnut, M4, Ext. Tooth Lockwasher, Stl, Zinc
37	22383292	Rear Cover, MB
38	224201	Gas Line Retainer
39	118236	Screw, M6 x 20
40	22385292	Rear Seam Molding, Matte Black Paint
	223852LNE	Rear Seam Molding, Linen Paint
41	157765	Front Safety Barrier Screen
42	157766	Side Safety Barrier Screen
43	226313	Side Plate Mounting Bracket, Left
44	226314	Side Plate Mounting Bracket, Right
45	225338	Magnet, .375" Dia x .25", Neo High Temp
46	224909	Cap, Silicone, .375" ID x .250" DP

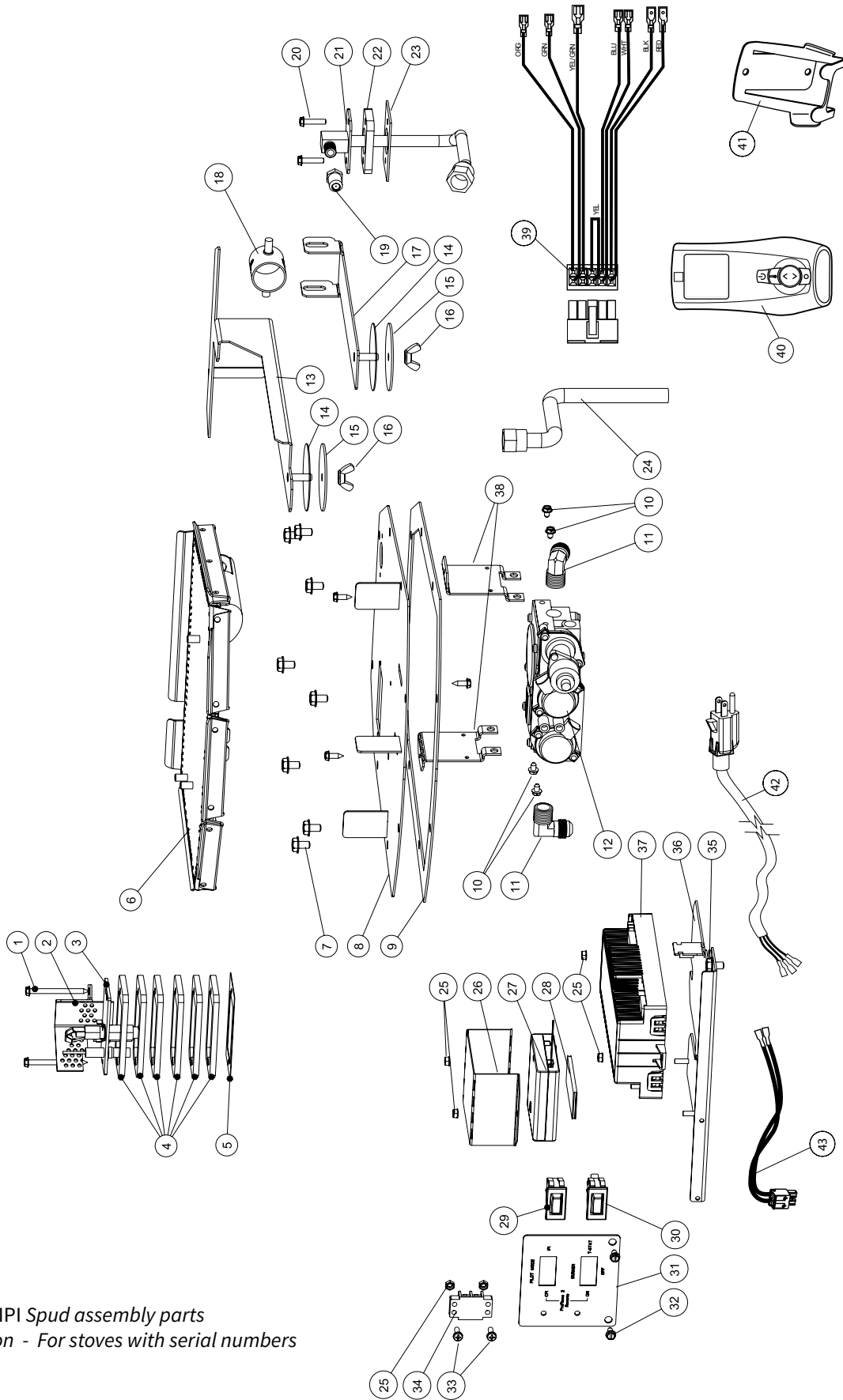

Figure 68.
 GF 370 DVII IPI Spud assembly parts
 identification - For stoves with serial numbers
 after 10000.

No.	Part Number	Description
1	118262	Screw, #8 X 1.75" SMS
2	223204	Pilot Air Deflector
3	158233	Pilot Assembly, NG, Flat Brkt, SS Body, 12" Tube
4	224791	Spacer, PSE Pilot, .188"
5	129670	Gasket, Pilot Assembly
6	156812	Burner Assembly, Complete
7	9962	Bolt, Hex Cap M6x10 DIN 933 8.8 Ser Flange Blk
8	225561	Weldment, PF2 Spud Plate
9	225581	Gasket, Spud Plate,
10	118214	Screw, #8 x 1/4", Taptite, SLHWH, SZPL
11	222292	Elbow, 90 deg, Brass 3/8 NTP X 3/8" Dia Tube
12	158130	Proflame 2 w/ Stepper Motor, NG
13	222987	Intake Restrictor
14	220734	Gasket, 2.25" OD x .125"
15	118023	Fender Washer, .250" x 2.25 "
16	117975	Wing Nut, M6
17	223201	Handle, Primary Air, GF 370
18	221390	Primary Air Shutter Asby
19	129130	Orifice, #38 / NG
	220731	Orifice, #53 / LP
20	117986	Screw, #8 x 3/4" SL HWH SMA Zinc
21	223231	Orifice Holder, Drop In Assembly
22	224132	Spacer, Orifice Holder
23	222280	Gasket, Drop In Orifice Holder
24	223235	Flex tube w/ connectors (3/8" OD x 48")
25	117922	Nut, Hex M4 DIN 934 Plain
26	225562	Battery Heat Shield
27	157265	Replacement IPI Back-up Battery Box (4 AA)
28	118257	Hook & Loop Tape, 1" wide, self-adhesive
29	120517	Rocker Switch, SPST, Blk, Plain
30	223201	Rocker Switch, SPDT, Center OFF, Blk, Plain
31	224781	Control Face Plate, Silkscreened, IPI Stoves
32	117917	Screw, HWH SMA #8 x 1/2" SL Blk Oxide
33	117921	Screw, Pan Hd M4 x 12mm, 8.8 M/S, Blk Oxide
34	129154	Terminal Block, 2 Pole 77 Series
35	9962	Bolt, Hex Cap M6 x 10mm DIN 933 Ser. Flng
36	22556092	Control Bracket
37	158130	Replacement Proflame 2 Control Board (POD)
38	225563	Valve Brackets, PF2
39	157493	Replacement Proflame 2 Wire Harness
40	157495	Replacement Multifunction Remote
41	223951BKP	Replacement Remote Wall Bracket
42	157492	Power Cord, 18 AWG, Grounded - 10 ft.
43	157494	Replacement Burner Control Wire Harness
44	223286	Center Log
45	223287	Right Log
46	223288	Left Log

Use only genuine Jøtul Replacement Parts available from your local Authorized Jøtul Dealer or by contacting:
 Jøtul North America
 55 Hutcherson Dr.
 Gorham, ME 04038
 207 591-6601

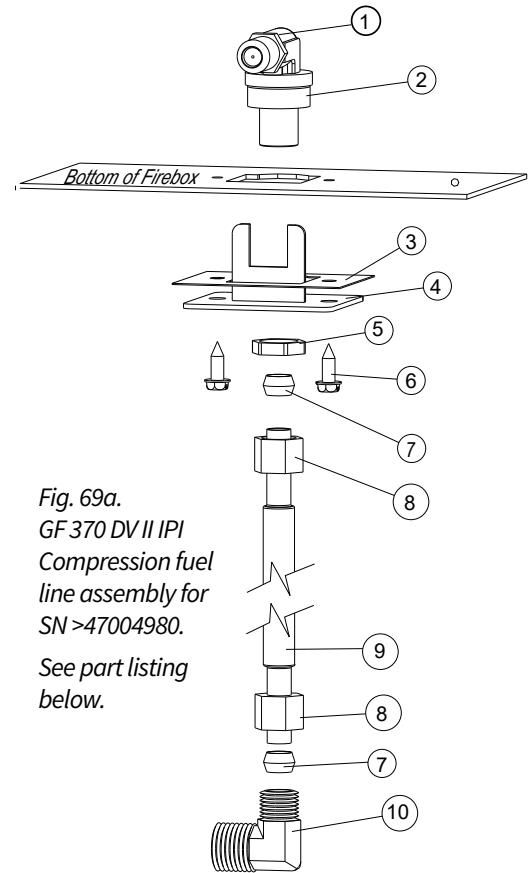
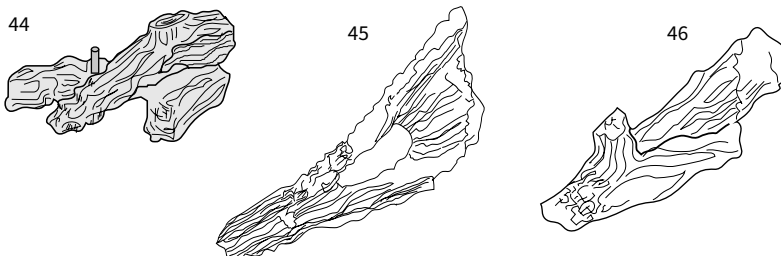

Fig. 69a.
 GF 370 DV II IPI
 Compression fuel
 line assembly for
 SN >47004980.
 See part listing
 below.

No.	Part Number	Description
1.	129130	Orifice, #38 / NG
	220731	Orifice, #53 / LP
2.	129668	Drop-in Orifice Holder
3.	226888	Gasket, Bottom-Mount Drop-in Holder
4.	226887	Bracket, Bottom-Mount Orifice Holder
5.	129152	Jam Nut, Orifice Holder Asy
6.	117917	Screw, #8 x 1/2" SM Blk Ox
7.	129463	Compression Sleeve, 5/16"
8.	129464	Compression Nut, 5/16"
9.	221769	Fuel Line, 10" x 5/16" ID Flex Tube
10.	129129	Brass Elbow, 90° 3/8 NTP x 5/16"



Jøtul GF 370 DV II IPI Limited Warranty

This warranty policy applies to gas products identified by Jøtul, Scan, and Atra trade names, as set forth below.

A. LIMITED FIVE YEAR WARRANTY - Cast Iron, Steel Doors, Surround Components, Firebox:

Jøtul North America Inc. (JØTUL) warrants, to the original retail purchaser, that those components of the Jøtul, Scan, or Atra Gas Stove or Fireplace specified above will be free of defects in material and workmanship for a period of five (5) years from the date of purchase. This warranty is subject to the terms, exclusions and limitations set forth in the following text.

B. LIMITED TWO YEAR WARRANTY - Burner, Burner Treatments, Firebox Panels:

JØTUL warrants, to the original retail purchaser, that those components of the Jøtul, Scan, or Atra Gas Stove or Fireplace specified above will be free of defects in material and workmanship for a period of two (2) years from the date of purchase. This warranty is subject to the terms, exclusions, and limitations set forth in the following text.

C. LIMITED TWO YEAR WARRANTY - Enamel Finish:

JØTUL warrants, to the original retail purchaser, the enamel finish on cast iron components of the Jøtul Stove or Fireplace Insert specified above against peeling or fading for a period of two (2) years from the date of purchase. This warranty is subject to the terms, exclusions and limitations set forth below.

D. LIMITED ONE YEAR WARRANTY - Gas & Electrical Components (controls, plumbing, valve, blower):

JØTUL warrants, to the original retail purchaser, that those components of the Jøtul, Scan, or Atra Gas Stove or Fireplace specified above will be free of defects in material and workmanship for a period of one (1) year from the date of purchase. This warranty is subject to the terms, exclusions, and limitations set forth in the following text.

JØTUL warrants, to the original retail purchaser, that those components of the Jøtul, Scan, or Atra Gas Stove or Fireplace specified above will be free of defects in material and workmanship for a period of one (1) year from the date of purchase. This warranty is subject to the terms, exclusions, and limitations set forth in the following text.

JØTUL will repair or replace (including parts & labor), at its option, any of the above components determined by JØTUL to be covered by this warranty. You must, at your own expense, arrange to deliver

or ship the component to an authorized Jøtul, Scan, or Atra dealer and arrange for pickup or delivery of the component after repairs have been made. If, upon inspection, JØTUL determines that the component is covered by this warranty, the repair or replacement will be made as set forth above. This warranty is not transferable and is extended only to, and is solely for the benefit of, the original retail purchaser of the Jøtul, Scan, or Atra Gas Stove or Fireplace. This paragraph sets forth the sole remedy available under this warranty in the event of any defect in the Jøtul, Scan, or Atra Gas Stove or Fireplace.

The warranty period for any replaced component will be the remaining unexpired portion of the warranty period for the original component.

Please retain your dated sales receipt in your records as proof of purchase.

EXCLUSIONS AND LIMITATIONS

NOTICE: This warranty is void if installation or service is performed by someone other than an authorized installer, service agency or gas supplier, or if installation is not in conformance with the installation and operating instructions contained in this owner's manual or local and/or national fire and building regulations. A listing of local authorized installers, service agencies and gas suppliers can be obtained from the National Fireplace Institute at <http://www.nficertified.org/>.

This warranty does not cover the following:

- 1) Repair or replacement of parts that are subject to normal wear and tear during the warranty period or to parts that may require replacement in connection with normal maintenance. These parts include paint, lamp bulbs, gaskets and glass (except to the extent such parts suffer damage from thermal stress).
- 2) Damage due to incorrect installations not in conformance with the installation instructions contained in this owner's manual or local and/or national fire and building regulations.
- 3) Damage due to service performed by an installer, service agency or gas supplier, unless otherwise agreed to in writing by JØTUL.
- 4) Labor or other costs associated with the repair of gas controls, plumbing, burners, log set, or sheet metal firebox beyond the warranty period.
- 5) Damage caused by unauthorized modification, use or repair.
- 6) Damage to enameled surfaces caused by improper operation or misuse, including use that is not in conformance with the operating instructions contained in this owner's manual. Such damage can typically be identified by bubbling, cracking, or discoloration of the enamel finish.
- 7) Costs incurred by travel time and/or loss of service.
- 8) Damage incurred while the Jøtul, Scan, or Atra Gas Stove or Fireplace is in transit.

IN NO EVENT SHALL JØTUL, ITS PARENT COMPANY, SHAREHOLDERS, AFFILIATES, OFFICERS, EMPLOYEES, AGENTS OR REPRESENTATIVES BE LIABLE OR RESPONSIBLE TO YOU FOR ANY SPECIAL, INDIRECT, INCIDENTAL, CONSEQUENTIAL, PUNITIVE OR OTHER SIMILAR DAMAGES, INCLUDING, BUT NOT LIMITED TO, LOST PROFITS, LOST SALES, INJURY TO PERSON OR PROPERTY, OR DAMAGES TO A STRUCTURE OR ITS CONTENTS, ARISING UNDER ANY THEORY OF LAW WHATSOEVER. ALL IMPLIED WARRANTIES, INCLUDING THE IMPLIED WARRANTIES OF MERCHANTABILITY AND FITNESS FOR A PARTICULAR PURPOSE, OR OTHERWISE, ARE LIMITED IN DURATION TO THE LENGTH OF THIS WRITTEN WARRANTY. EXCEPT AS EXPRESSLY SET FORTH HEREIN, JØTUL MAKES NO ORAL, WRITTEN OR OTHER WARRANTY WITH RESPECT TO JØTUL, SCAN OR ATRA GAS STOVES OR

FIREPLACES.

Some states do not allow the exclusion or limitation of incidental or consequential damages, or limitations on the length of implied warranties. Therefore, the above exclusions or limitations may not apply to you. This warranty gives you specific legal rights, and you may have other rights, which vary from state to state.

JØTUL reserves the right to discontinue, modify or change the materials used to produce the Jøtul, Scan, or Atra Gas Stove or Fireplace. JØTUL shall have the right to replace any defective component with substitute components determined by JØTUL to be of substantially equal quality and price.

The dollar value of JØTUL's liability for breach of this warranty shall be limited exclusively to the cost of furnishing a replacement component. JØTUL shall not in any event be liable for the cost of labor expended by others in connection with any defective component. Any costs or expenses beyond those expressly assumed by JØTUL under the terms of this warranty shall be the sole responsibility of the owner(s) of the Jøtul, Scan, or Atra Gas Stove or Fireplace.

No dealer, distributor, or other person is authorized to modify, augment, or extend this limited warranty on behalf of JØTUL. NO MODIFICATION OR CHANGE TO THIS WARRANTY WILL BE EFFECTIVE UNLESS IT IS MADE IN A WRITTEN DOCUMENT MANUALLY SIGNED BY AN AUTHORIZED OFFICER OF JØTUL.

An authorized installer may have been provided with certain information related particularly to the Jøtul, Scan, or Atra Gas Stove or Fireplace; however, no authorized installer or other person who may service the appliance is an agent of JØTUL. No inference should be made that JØTUL has tested, certified, or otherwise pronounced any person as qualified to install or service the appliance. JØTUL shall not be liable or otherwise responsible for any error or omission by a person installing or servicing a Jøtul, Scan, or Atra Gas Stove or Fireplace.

If you believe your Jøtul, Scan, or Atra Gas Stove or Fireplace is defective, you should contact your nearest authorized Jøtul, Scan, or Atra dealer, who will process a warranty claim. IN ORDER TO QUALIFY FOR WARRANTY COVERAGE, JØTUL MUST RECEIVE NOTICE OF A POSSIBLE DEFECT WITHIN SIXTY (60) DAYS OF THE DATE THE DEFECT IS FIRST DISCOVERED, OR REASONABLY COULD HAVE BEEN DISCOVERED.

**This warranty is given by Jøtul North America, Inc.,
55 Hutcherson Drive, Gorham, Maine 04038 USA**

Your stove has a unique serial number stamped on the rating plate which is located in the valve compartment. Please record the serial number in the space below. You may also wish to attach your purchase receipt to this page for future reference.

MODEL NAME: Jøtul GF 370 DV II IPI Gas Stove

SERIAL NUMBER: _____

PURCHASE DATE: _____

AUTHORIZED DEALER: _____

ADDRESS _____

PHONE: _____

INSTALLER: _____

FUEL TYPE: _____

FUEL CONVERSION: NO _____ YES _____

NOTES: _____

LIGHTING INSTRUCTIONS

FOR YOUR SAFETY, READ BEFORE LIGHTING.

WARNING:
IF YOU DO NOT FOLLOW THESE INSTRUCTIONS EXACTLY, A FIRE OR EXPLOSION MAY RESULT CAUSING PROPERTY DAMAGE, PERSONAL INJURY, OR LOSS OF LIFE.

- A. This appliance is equipped with an ignition device which automatically lights the pilot. Do not try to light the pilot by hand.
- B. BEFORE LIGHTING, smell all around the appliance area for gas. Be sure to smell next to the floor because some gas is heavier than air and will settle to the floor.
- WHAT TO DO IF YOU SMELL GAS:
- Extinguish any open flame.
 - Open windows.
 - Do not light any appliance.
 - Do not touch any electrical switches.
 - Do not use any phone in your building.
 - Immediately call your gas supplier from a neighbor's phone.
- If your gas supplier cannot be reached, call the fire department.
- C. Use only your hand to push in or turn the gas control knob. Never use tools. If the knob will not push in or turn by hand, do not try to repair it. Call a qualified technician. Force or attempted repair may result in a fire or explosion.
- D. Do not use this appliance if any part has been under water. Immediately call a qualified service technician to inspect the appliance and to replace any part of the control system and any gas control which has been under water.

LIGHTING INSTRUCTIONS

1. STOP! Read the safety information above.
2. Set the thermostat to the lowest setting.
3. Set the Burner switch to the "OFF" position.
4. This appliance is equipped with an ignition device which automatically lights the pilot. Do not try to light the pilot by hand.
5. Wait five (5) minutes to clear out any gas. Then smell for gas, including near the floor. If you smell gas, STOP! Follow "B" in the safety information above on this label. If you do not smell gas, go to the next step.
6. Set the Pilot Mode switch to CPI for continuous operation. The pilot will ignite and remain lit for up to seven days, if desired. Set Pilot to IPI for thermostatic operation. The pilot will light when there is a call for heat.
7. Set the Burner switch to the "ON" or "T-STAT" position.
8. Set the thermostat to the desired setting to light the burner. If the appliance will not operate, follow the instructions, "To Turn Off Gas To Appliance", and call your service technician or gas supplier.

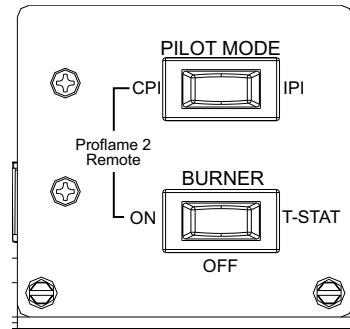

PILOT MODE AND BURNER CONTROLS

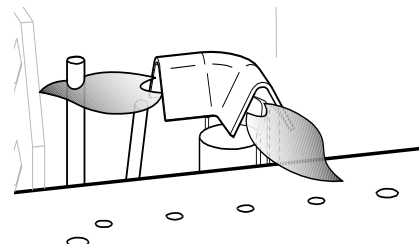

PILOT LIGHT FLAME PATTERN

TO TURN OFF GAS TO THE APPLIANCE:

1. Set the thermostat to the lowest setting.
2. Set the Burner Control Switch to the "OFF" position.
3. Turn off all electrical power to the appliance if service is to be performed.
4. Close control access door.

139647_R29
October 2023

This appliance must be installed in conformance with local and national building regulations. Before beginning the installation, it is important that these instructions be carefully read and understood. Jøtul maintains a policy of continual product development. Consequently, products may differ in specification, color or type of accessories from those illustrated or described in various publications.

Manufactured by

Jøtul North America

55 Hutcherson Dr.
Gorham, ME 04038-2634
U.S.A.

Jøtul AS
P.O. Box 1411
N-1602 Fredrikstad
Norway



www.jotul.us