

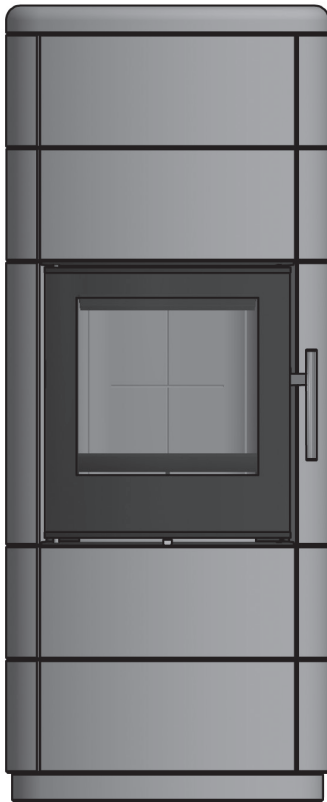

Marcello Wood-Burning Soapstone Stove

Installation, and Operating Manual rev: 2/12/20



INSTALLER: Leave this manual with the party responsible for use and operation.

OWNER: Save this manual for future reference. Do not discard!

QUESTIONS: Call your Authorized Dealer.

Installation and repairs of this appliance must be performed by authorized technicians. Norsk Kleber recommends trained professionals in HTT or NFI certified factories.



SAFETY NOTICE

If this solid fuel room heater is not properly installed, assembled and used, a house fire may result. For your safety, follow the installation directions. Contact local building or fire officials about restrictions and installation inspection requirements in your area.

CAUTION

Tested and approved to use with dry, seasoned wood only. Do not burn wet or green wood. Burning any other type of fuel may be a danger and will void your warranty.

WARNING

Please read this entire manual before installation and use of this wood-burning room heater. Failure to follow these instructions could result in property damage, bodily injury, or even death.

1. Do not store or use gasoline or other flammable vapors and liquids in the vicinity of this or any other appliance.
2. Do not overfire - If any external part starts to glow, you are overfiring. Close air controls. Overfiring will void your warranty.
3. Comply with all minimum clearances to combustibles as specified.

IMPORTANT

Record the following information to help your dealer determine what you will need, should your stove ever require parts or service.

The serial number and manufacturing date are located on the Safety Label at the lower back part of the stove. Attach your sales receipt to this manual for future reference.

Model: Marcello

Serial Number: _____

Purchase Date: _____

Dealer Name: _____

Dealer Phone: _____

Installed By: _____

Table of Contents

Specifications and Safety Notices	_____	Page 1
Stove Dimensions	_____	Page 5
Design Considerations	_____	Page 6
Installation Instructions	_____	Page 7
Parts List	_____	Page 14
Exploded View	_____	Page 15
Assembly Manual	_____	Page 17
Use and Maintenance	_____	Page 29
Warranty Information	_____	Page 34

Test & Listing Standards

The Marcello Solid Fuel Room Heater has been tested for compliance with the applicable requirements of the following standards:

UL 1482-2011 (R2015) “Solid-Fuel Type Room Heaters” and ULC-S627-00 (R2016) “Standard for Space Heaters for use with Solid Fuels”.

Certified Safety Tests performed by PFS-TECO – Clackamas, Oregon, USA

Report Number: 19-515



Environmental Protection Agency (EPA): This appliance is a “Masonry Heater” and because of its efficiency is not subject to EPA regulation and certification.

Manufacturer: Norsk Kleber AS, Skansen 29, 2670 Otta, Norway

Safety Notices

Carefully read the instructions for assembly, use, and maintenance provided with the masonry heater before using the masonry heater.

- This manual describes the installation and operation of the Marcello non-catalytic wood heater. Save these instructions and make them available to anyone using or servicing the stove. Read the entire manual before you install and use your new wood stove.
- This wood heater needs periodic inspection and repair for proper operation. See this manual for specific information. It is against federal regulations to operate this wood heater in a manner inconsistent with the operating instructions in this Owner’s Manual.
- **THIS APPLIANCE IS NOT APPROVED FOR USE IN MOBILE HOMES**
- The Marcello is Listed to burn solid or compressed wood only. Do not burn any other fuels.
- Max. Log Length: 12 in. / 300 mm

Safety Notices



- **NOT USE CHEMICALS OR FLUIDS TO START THE FIRE. DO NOT BURN GARBAGE, TRASH, OR FLAMMABLE FLUIDS.**
- **IF THIS ROOM HEATER IS NOT PROPERLY INSTALLED, A HOUSE FIRE MAY RESULT. TO REDUCE THE RISK OF FIRE, FOLLOW THE INSTALLATION INSTRUCTIONS. FAILURE TO FOLLOW THESE INSTRUCTIONS MAY RESULT IN PROPERTY DAMAGE, BODILY INJURY, OR LOSS OF LIFE.**
- **CONTACT THE LOCAL BUILDING OR FIRE OFFICIALS ABOUT RESTRICTIONS AND INSTALLATION INSPECTION REQUIREMENTS IN YOUR AREA. WHEN NOT ADDRESSED IN THIS MANUAL, OR BY LOCAL CODE AUTHORITIES, INSTALLATION SPECIFICATIONS AND REQUIREMENTS DEFER TO NFPA 211 OR CSA B 365.**
- **DO NOT CONNECT THIS Stove TO ANY AIR DISTRIBUTION DUCT OR SYSTEM.**
- **EXTREMELY HOT WHILE IN OPERATION! KEEP CHILDREN, CLOTHING AND FURNITURE AWAY. CONTACT WILL CAUSE SKIN BURNS.**
- **NEVER LEAVE SMALL CHILDREN UNSUPERVISED IN THE SAME ROOM WITH THE STOVE. USE A CHILD-GUARD SCREEN OR OTHER BARRIER TO PROTECT CHILDREN FROM ACCIDENTAL CONTACT.**
- **NEVER OPERATE THE Stove WITH A CRACKED OR BROKEN GLASS PANEL.**
- **Install smoke detectors in the living areas and bedrooms of your home. Test them regularly and install new batteries twice annually. When installed in the same room as the stove, a smoke detector should be located as far from the stove as possible to prevent it from sounding when adding fuel to the fire. Some jurisdictions require installation of CO (carbon monoxide) detectors. Check your local codes.**

- Avoid creating a low pressure condition in the room where the stove is operating. Be aware that operation of an exhaust fan or clothes dryer can create a low pressure area and consequently promote flow reversal through the stove and chimney system. The chimney and building, however, always work together as a system - provision of outside air, directly or indirectly to an atmospherically vented appliance will not guarantee proper chimney performance. Consult your local Norsk Kleber authorized dealer regarding specific installation or performance issues.
- Never fire while the stove door is open.
- In case of soot fire: close the stove's draft adjustment immediately and call 911.
- **WARNING: THIS WOOD-BURNING HEATER HAS A MANUFACTURER-SET MINIMUM LOW BURN RATE THAT MUST NOT BE ALTERED. IT IS AGAINST FEDERAL REGULATIONS TO ALTER THIS SETTING OR OTHERWISE OPERATE THIS WOOD HEATER IN A MANNER INCONSISTENT WITH OPERATING INSTRUCTIONS IN THIS MANUAL.**
- Check building codes.

When installing, operating and maintaining your Marcello model, follow the guidelines presented in these instructions, and make them available to anyone using or servicing the stove. In the U.S., guidelines established by UL 1777, the National Fire Protection Association's Code, NFPA 211, Standards for Chimneys, Stoves, Vents and Solid Fuel Burning Appliances, or similar regulations, may apply to the installation of a solid fuel burning appliance in your area. For further information on using your heater safely, obtain a copy of the NFPA publication "Using Coal and Wood Stoves Safely," NFPA No. HS-8-1974, available from NFPA 470 Atlantic Ave. Boston, MA 02210.

In Canada, the guidelines are established by ULC-S635, and the CSA Standard, CAN/CSA-B365-M93, Installation Code for Solid-Fuel-Burning Appliances and Equipment. Always consult your local building inspector or authority having jurisdiction to determine what regulations apply and what permits may be required before installation of a solid fuel-burning appliance.

WARNING 

If glass requires replacement only use: Schott or Nippon ceramic glass, with a thickness of 5 mm.

WARNING 

Chimney connector must be in good condition and kept clean.

California Safety Information

WARNING

This product and the fuels used to operate this product (wood), and the products of combustion of such fuels, can expose you to chemicals including carbon black, which is known to the State of California to cause cancer, and carbon monoxide, which is know to the State of California to cause birth defects or other reproductive harm. For more information go to: www.P65Warnings.ca.gov

Proposition 65 Warning: Fuels used in gas, woodturning or oil fired appliances, and the products of combustion of such fuels, contain chemicals known to the State of California to cause cancer, birth defects and other reproductive harm.

California Health & Safety Code Sec. 25249.6

Marcello Soapstone Stove Dimensions

Marcello 140

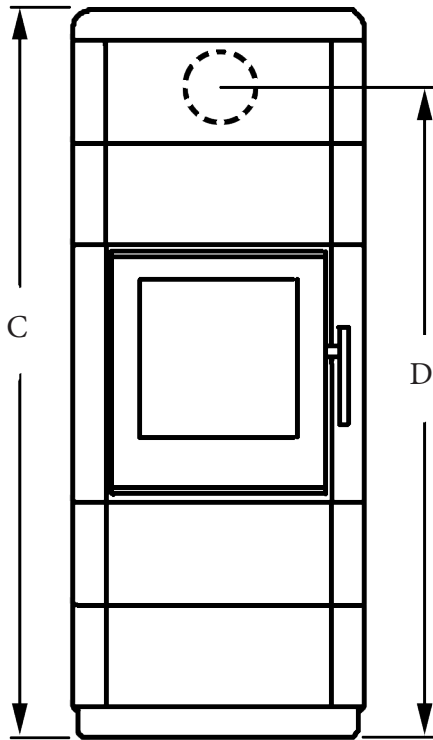

Marcello 120

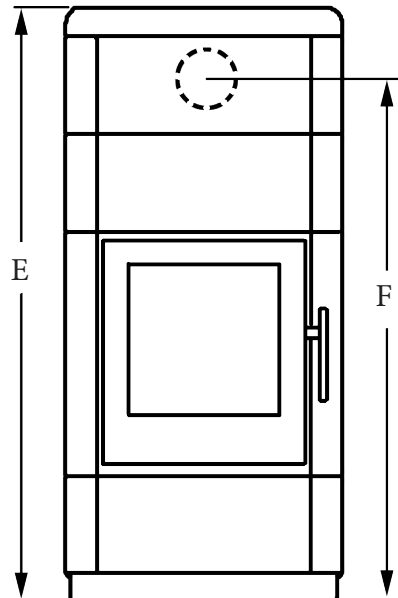

Marcello 110

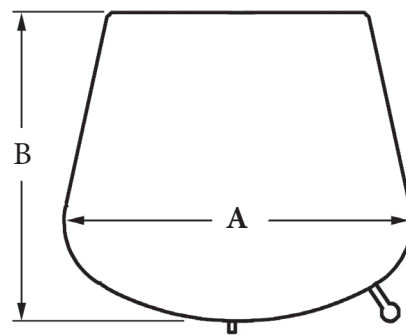
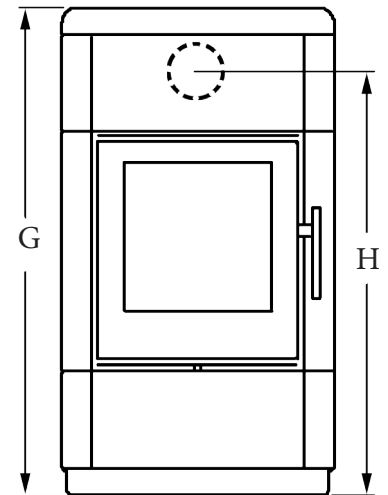

A	B	C	D	E	F	G	H
21.65 in.	18.9 in.	55.12 in.	48.82 in.	47.24 in.	40.95 in.	39.37 in.	33.07 in.
550 mm	480 mm	1400 mm	1240 mm	1200 mm	1040 mm	1000 mm	840 mm

Design Considerations

When selecting a chimney type and the location for the chimney in the house, keep this in mind: It is the chimney that makes the stove work - not the stove that makes the chimney work. This is because a chimney actually creates a suction, called “draft” which pulls air through the stove.

Several factors affect draft: chimney height, cross-sectional area (size), and temperature of the chimney, as well as the proximity of surrounding trees or buildings.

A short exterior masonry chimney will give the poorest performance because it will be difficult to warm the flue and sustain the temperatures necessary to maintain draft strength. In extremely cold climates, it may be necessary to reline the chimney or extend the height to help establish draft.

A tall, interior masonry chimney is easier to keep warm and will perform the best under a variety of weather and environmental conditions.

The following guidelines give the necessary chimney requirements based on the national code (ANSI-NFPA 211 for the US. And CSA CAN-B365 for Canada). However, many local codes differ from the national code to take into account climate, altitude, or other factors. Your local building inspector is the final approving authority.

Masonry Chimneys

Follow these guidelines when installing the stove into a masonry stove:

- The masonry chimney must have a fireclay liner or equivalent, with a minimum thickness of 5/8” (14 mm) and must be installed with refractory mortar. There must be at least 1/2” (12.7 mm) air space between the flue liner and chimney wall.
- The fireclay flue liner must have a nominal size of 8” X 8” (20 cm x 20 cm), and should not be larger than 8”X 12” (20 cm x 30 cm). A round fireclay liner must have a minimum inside diameter of 6” (15 cm) and maximum inside diameter of 8” (20 cm). A larger chimney should be relined with an appropriate code approved liner.

- Brick or modular block must be a minimum of 4” (10 cm) nominal thickness. Stone construction must be at least 12” (30 cm) thick.
- A newly-built chimney must conform to local codes, or, in their absence, must comply with national regulations.
- An existing chimney must be inspected by a professional, licensed chimney sweep, fire official, or code officer to ensure that the chimney is in proper working order. Any repairs must be completed before installing the stove.
- No other appliance may be vented into the same flue.
- An airtight clean-out door should be located at the base of the chimney.

Chimney Height

- The chimney must be at least 15 feet high (4.57 m). The chimney must also be at least 3 feet (92 cm) higher than the highest point where it passes through the roof and at least 2 feet (61 cm) higher than the highest part of the roof or structure that is within 10 feet (3.05 m) of the chimney, measured horizontally. See Fig 2.
- Chimneys shorter than 15 feet may not provide adequate draft. Inadequate draft can result in smoke spillage when loading the stove, or when the door is open. Poor draft can also cause back puffing (ignition of gas build-up inside the firebox) and sluggish performance. The minimum height does not, in itself, guarantee proper chimney performance. Optimum draft force should be in the .05 - .10 in. w.c. range measured by a Magnehelic gauge. Draft at .07 w.c. is ideal.
- Excessive chimney height can promote over-strong draft resulting in high stove temperatures and short burn times. Excessive draft can be corrected by installing a butterfly damper. Your dealer is an expert resource to consult regarding draft issues or other performance-related questions.

INSTALLATION

NORSK KLEBER REQUIRES ALL INSTALLATION AND ASSEMBLY OF THIS STOVE TO BE PERFORMED BY TRAINED PROFESSIONALS.

CAUTION: 

Follow these installation instructions in all cases.

When installing, operating and maintaining your Babina+ model, follow the guidelines presented in these instructions, and make them available to anyone using or servicing the stove. In the U.S., guidelines established by UL 1777, the National Fire Protection Association's Code, NFPA 211, Standards for Chimneys, Stoves, Vents and Solid Fuel Burning Appliances, or similar regulations, may apply to the installation of a solid fuel burning appliance in your area. For further information on using your heater safely, obtain a copy of the NFPA publication "Using Coal and Wood Stoves Safely," NFPA No. HS-8-1974, available from NFPA 470 Atlantic Ave. Boston, MA 02210.

In Canada, the guidelines are established by ULC-S635, and the CSA Standard, CAN/CSA-B365-M93, Installation Code for Solid-Fuel-Burning Appliances and Equipment.

Always consult your local building inspector or authority having jurisdiction, to determine what regulations apply and what permits may be required before installation of a solid fuel-burning appliance.

Notify your insurance company before installing this stove.

Chimney Requirements

There are two types of approved chimneys:

1. A code-approved masonry chimney with a ceramic tile or Listed steel flue liner.
2. A prefabricated chimney complying with the requirements for Type HT (2100°F) chimneys per UL 103 HT or ULC S629 HT.

Chimney Flue Sizing

- The chimney size should not be less than the cross-sectional area of the flue collar, and not more than three times greater than the cross-sectional area of the flue collar.
- If the chimney flue is outdoors, its cross-sectional area may not exceed two times greater than the stove flue collar.
- A chimney flue having no walls exposed to the outside below the roof-line may be no larger than three-times the cross-sectional area of the stove flue collar.

Installation and repairs of this appliance must be performed by authorized technicians. Norsk Kleber recommends trained professionals in HTT or NFI certified factories.



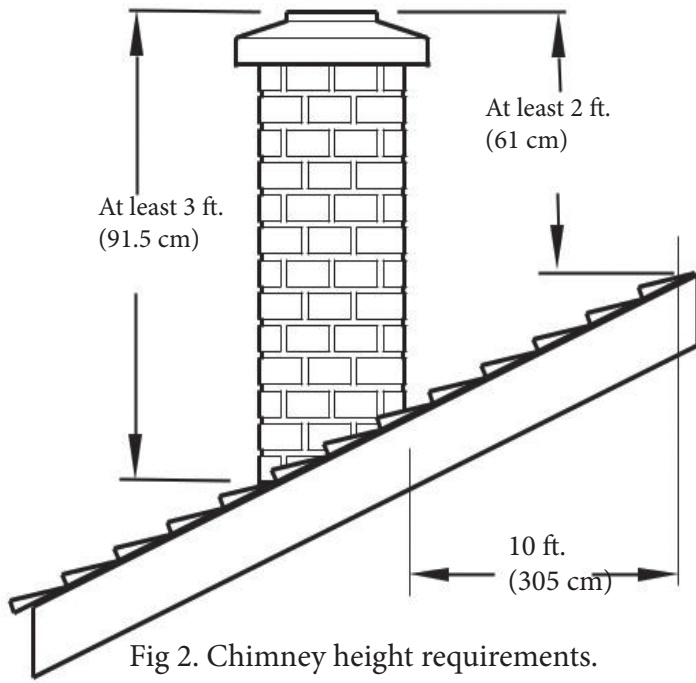

Fig 2. Chimney height requirements.

- The maximum horizontal run should not exceed 3 ft. (92 cm) with a 1/4" rise per foot. Under no circumstance should horizontal pipe be allowed to slant down toward the chimney.
- No part of the chimney connector may pass through an attic or roof space, closet or other concealed space, or through a floor or ceiling.
- All sections of the chimney connectors must be accessible for cleaning. Where passage through a wall or partition of combustible construction is desired, the installation must conform with NFPA 211 or CAN/ CSA-B365, and is also addressed in this manual.
- Do not connect this stove to a chimney flue serving another heating appliance.

Chimney Connector Requirements

Use 6" single wall or Listed 6" double-wall stovepipe to connect the stove to the chimney. Single wall stovepipe must be black steel or stainless steel and have a minimum thickness of 24 gauge.

Do not use aluminum or galvanized steel pipe for chimney connection - these materials are not suitable for use with solid fuel.

Follow these guidelines:

- Do not use chimney connector as a chimney. It is intended only as a connection device.
- Each connector section must be oriented with the male (crimped) end pointing toward the stove. See Fig 3.
- Secure all connector joints with three sheet metal screws. Use four self-tapping sheet metal screws at the connection to the stove flue collar adaptor.
- For the best performance, the chimney connector should be as short and direct as possible, including no more than two 90° elbows.
- The maximum vertical run of single wall stovepipe should not exceed 10 ft. (305 cm).

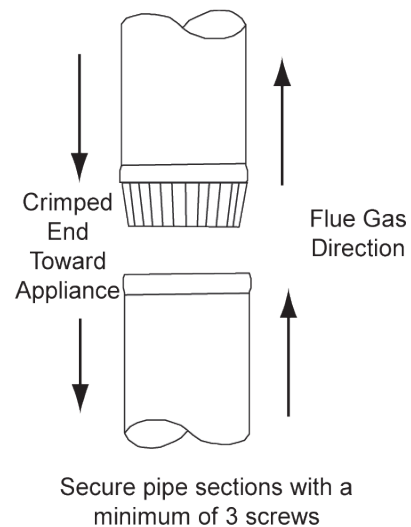

Fig 3

Connecting to the Chimney

Masonry Chimney

When installing a Stove into a masonry chimney through a “thimble” (the opening through the chimney wall to the flue), the thimble must consist of ceramic tile or steel and be securely cemented in place.

The chimney connector/stove pipe must slide completely inside the thimble to the inner surface or the flue liner. It may be necessary to make use of a thimble sleeve (a pipe with a slightly smaller diameter than standard stove pipe). See Fig 4.

The connector pipe or thimble sleeve must not protrude into the flue liner or otherwise restrict draft. Use refractory cement to seal the seam between the chimney connector, sleeve, and thimble.

Do not connect this stove to a chimney flue servicing another appliance of any kind.

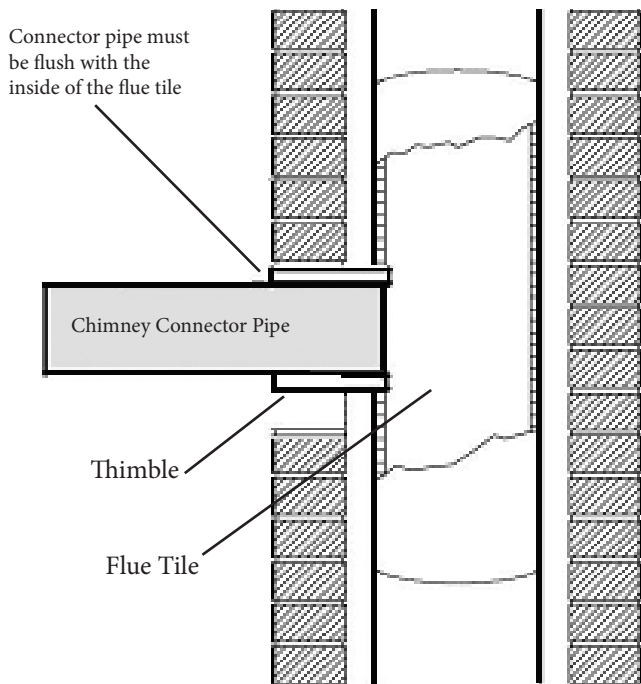

Fig 4 Masonry chimney connection through a thimble.

Prefabricated Chimneys

When connecting the Babina+ to a prefabricated metal chimney always follow the pipe manufacturer’s instructions and be sure to use the components that are required. This usually includes a “smoke pipe adapter” that is secured to the bottom section of the metal chimney and allows the chimney pipe to be secured to it with two sheet metal screws. See Fig 5.

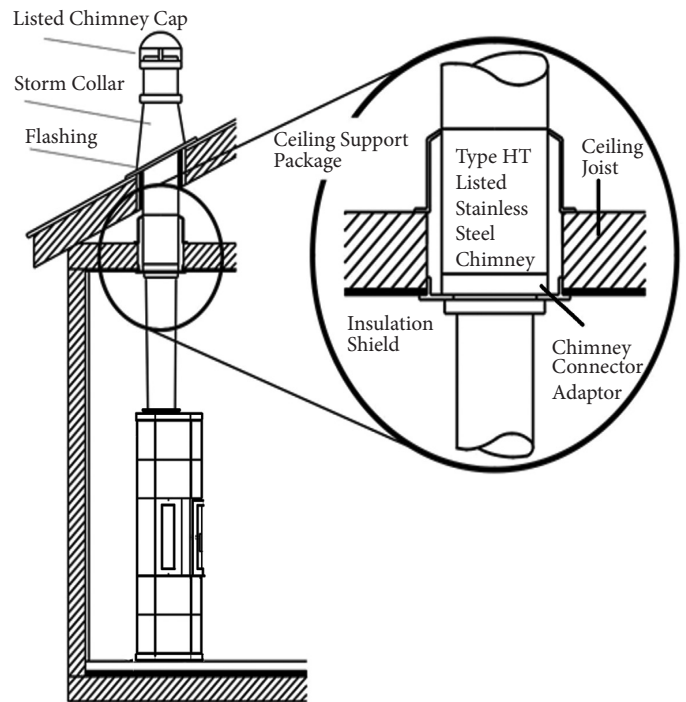

Fig 5. Connection to prefabricated chimney.

Note: In addition to the methods described here, any listed, prefabricated wall pass-through components available from chimney manufacturers may be used.

In the U.S.

The National Fire Protection Association's publication, NFPA 211, Standard for Chimneys, Stoves, Vents and Solid Fuel Burning Appliances permits four methods for passing through a combustible wall. Before proceeding with any method be sure to consult with your local building officials to discuss any local code requirements.

Common Method:

See Fig 6. Remove all combustible materials from the pass-through area (around the chimney connector), a minimum 12" (30.5 cm). A 6" (15.2 cm) diameter connector will require a 31 1/4" x 31 1/4" (79.4 x 79.4 cm) square opening.

The opening must be filled with at least 12" (30.5 cm) of brick around a fireclay liner. The liner must be ASTM C35 or equivalent, having a minimum wall thickness of 5/8" (16 mm).

The Pass-through must be at least 18" (45.7 cm) from combustible ceiling materials.

It will be necessary to cut wall studs, install headers, and construct a sill frame to maintain the proper dimensions and to support the weight of the brick.

The bricks must be solid brick with a minimum of 3 inches thick (nominal 4" / 102 mm).

Refractory mortar must be used at the junction of the chimney and the pass-through liner. The pass-through liner must not penetrate the chimney liner beyond the inner surface of the chimney liner. Use extreme care when constructing the hole in the chimney liner as the tiles can shatter easily.

Consult your local building inspector, authorized Norsk Kleber Dealer, NFPA 211 in the U.S. or CAN/CSA-B635 in Canada for other approved wall pass-through methods.

In Canada

The installation must conform to CAN/CSA-B365, Installation Code for Solid Fuel Burning Appliances and Equipment. Before proceeding be sure to consult your local building inspector.

Common Method:

This method requires the removal of all combustible materials from at least 18" (45.7 cm) around the chimney connector's proposed location. A 6" round liner requires a minimum opening 43 1/4" x 43 1/4" (109.8 x 109.8 wcm) square.

Locate the pass-through at least 18" from combustible ceiling materials. The space that is cleared of combustible materials must remain empty. Sheet metal panels can be used to cover the area. However, when using a panel on both sides of the wall, each cover must be installed on noncombustible spacers at least 1" from the wall. If one panel of sheet metal is to be used it may be installed flush to the wall.

See section 5.3.1 and 5.3.2 of CAN/CSA - B365-M91.

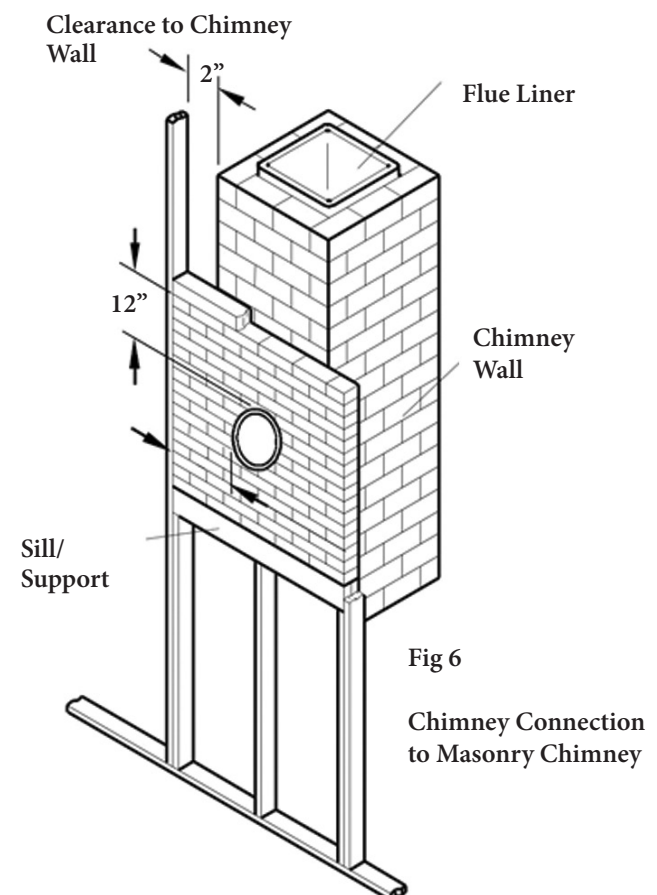

Floor Protection

Any floor that is not composed of concrete poured on earth requires protection from sparks and embers. The Babina+ is approved for installation using one of the following forms of hearth protection:

1. Any UL, ULC, or Warnock Hersey Listed Type 1 hearth board.
2. Any noncombustible material.

In the U.S. floor protection must extend continuously forward from the door opening at least 16 in. and 8 in. from the sides of the door opening. Protection must also extend 2 in. under the chimney connector. This will result in a minimum floor protector 35 3/4" wide x 36 1/2" deep. See **Fig 7**.

In Canada, floor protection must extend continuously 18" from the front of the stove and 8 in. (460 mm) from the sides and rear. It must also extend 2 in. (51 mm) to both sides under a horizontal chimney connector section. This results in a floor protector 35 in. x 45 in. (89 cm x 114 cm). See **Fig. 7**.

Fig 7. Floor protection dimensions

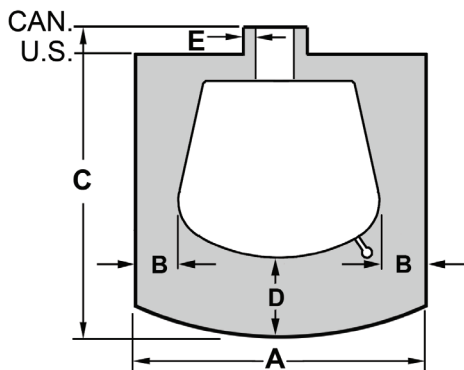

	A	B	C	D	E
U.S.	36.47 in.	8 in.	35 in.	16 in.	2 in.
	926 mm	203 mm	889 mm	406 mm	51 mm
CAN	35.75 in.	8 in.	45 in.	18 in.	2 in.
	908 mm	203 mm	1143 mm	457 mm	51 mm

Clearance to Combustible Materials

The clearances listed and diagrammed in this manual have been tested to UL and ULC standards and are the minimum clearances to combustible materials specifically established for the Norsk Kleber +models.

A combustible surface is anything that can burn (i.e. sheet rock, wall paper, wood, fabrics etc.). Any combustible material must be kept 36" (914 mm) away from the stove load door and at least 18" (457 mm) from the sides.

Combustible materials are not limited to those that are visible and also include materials that are behind noncombustible materials. "Fire Resistant" or "Fire-rated" materials are considered combustible; they are difficult to ignite, but will burn.

Consult your local fire officials if you are unsure of the combustible nature of any material.

Clearance to Walls & Ceilings

See the table in **Fig. 8** for specific wall clearance requirements using either single or listed double-wall connectors.

Minimum Ceiling Height: 84" / 213 cm

Minimum Ceiling Clearance: 30" / 76 cm

The Babina+ is approved for use with Listed double wall pipe installed to conform to the clearances in **Fig. 8a**.

Wall-Mounted Protection: When reducing clearances through the use of wall-mounted protection: For the U.S., refer to NFPA 211, Standard for Chimneys, Stoves, Vents and Solid Fuel Burning Appliances, for acceptable materials, proper sizing and construction guidelines.

For Canada, refer to CAN/CSA-B365, Installation Code for Solid-Fuel Burning Appliances and Equipment, also for acceptable materials, proper sizing and construction guidelines.

Notice: Many manufacturers have developed woodburning stove accessories that permit clearance reduction. Use only those accessories that have been tested by an independent laboratory and carry that laboratory's testing mark. Be sure to follow all of the manufacturer's instructions.

Clearance to Combustible Materials

Fig 8

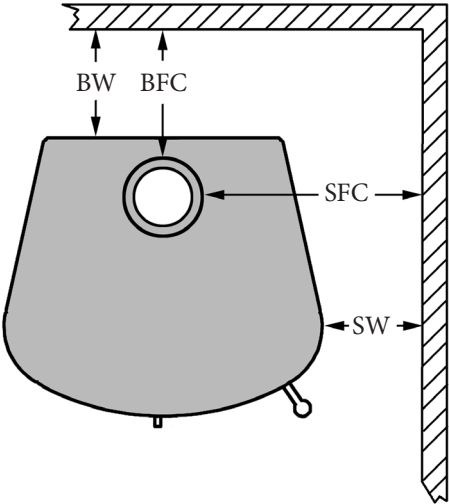

Fig 8

SW	Side Wall to Side	15 inch	381 mm
SFC	Side Wall to Flue Collar	23 inch	584 mm
BW	Back Wall to Unit	15 inch	381 mm
BFC	Back Wall Flue Collar	17 inch	432 mm

Fig 8b

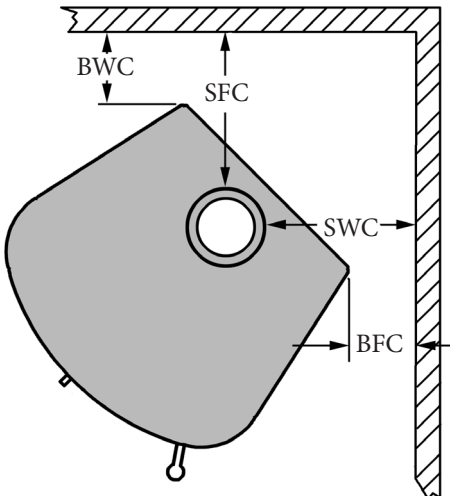

Fig 8b

SWC	Side Wall to Corner	12 inch	305 mm
SFC	Side Wall to Flue Collar	19 inch	483 mm
BWC	Back Wall to Corner	12 inch	305 mm
BFC	Back Wall Flue Collar	19 inch	483 mm

Stove requires noncombustible floor protection

Chimney Connector Clearances

The stove position will be determined by the greater of either the stove clearance or the chimney connector clearance above (x) and to the side (y). See **Fig. 9**.

Single Wall Pipe:

Unprotected Surface: 18"/485 mm

Protected Surface: 6"/153 mm

Double Wall Pipe: Mfg's Listing

Chimney Connection

Use 6 in. flue connector made
form 24 gauge or heavier
steel.

Chimney Connector Clearances:

The stove position will be determined by the greater of either the stove clearance or the chimney connector clearance above (x) and to the side (y).

(x) Connector to Ceiling 19"

(y) Connector to Parallel Wall 19"

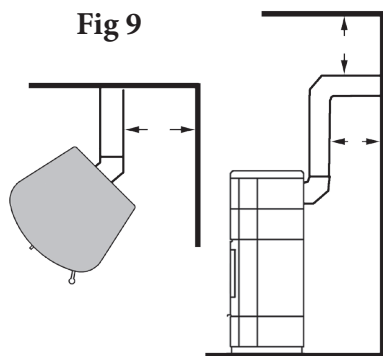

**Rear exit chimney
connector clearance**

Notice: Many manufacturers have developed woodburning stove accessories that permit clearance reduction. Use only those accessories that have been tested by an independent laboratory and carry that laboratory's testing mark. Be sure to follow all of the manufacturer's instructions.

Clearance to Combustible Materials

- The clearances listed and diagramed in this manual have been tested to UL and ULC standards and are the minimum clearances to combustible materials specifically established for the Norsk Kleber Babina+ models.
- A combustible surface is anything that can burn (i.e. sheet rock, wall paper, wood, fabrics etc.).
- Any combustible material must be kept 36" (914 mm) away from the stove load door and at least 18" (457 mm) from the sides.
- Combustible materials are not limited to those that are visible and also include materials that are behind noncombustible materials. "Fire Resistant" or "Fire-rated" materials are considered combustible; they are difficult to ignite, but will burn.
- Consult your local fire officials if you are unsure of the combustible nature of any material.

Clearance to Walls & Ceilings

See the table in **Fig. 8** for specific wall clearance requirements using either single or Listed double-wall connectors.

Minimum Ceiling Height: 84"/ 213 cm

Minimum Ceiling Clearance: 30"/ 76 cm

The Marcello is approved for use with Listed double wall pipe installed to conform to the clearances in **Fig. 9**.

Wall-Mounted Protection: When reducing clearances through the use of wall-mounted protection:

For the U.S., refer to NFPA 211, Standard for Chimneys, Stoves, Vents and Solid Fuel Burning Appliances, for acceptable materials, proper sizing and construction guidelines.

For Canada, refer to CAN/CSA-B365, Installation Code for Solid-Fuel Burning Appliances and Equipment, also for acceptable materials, proper sizing and construction guidelines.

Parts List

Part No.	Description	Marcello 100	Marcello 120	Marcello 140
08-01-01	Extension 125-150mm	1	1	1
01-28-01	Marcello bottomplate	1	1	1
01-28-02	Marcello front stone, 20 cm	2	3	4
01-28-03	Marcello corner stone, 20 cm	4	6	8
01-28-04	Marcello side stone, 20 cm	4	6	8
01-28-05	Marcello rearstone with air hole	1	1	1
01-28-06	Marcello pillars for burn plate, low	2	2	0
01-28-07	Marcello burn plate	1	1	1
01-28-08	Marcello corner stone for door section	2	2	2
01-28-09	Marcello side stone for door section	2	2	2
01-28-10	Marcello rear stone for door section	1	1	1
01-28-13	Marcello baffle, back	1	1	1
01-28-14	Marcello baffle stone	2	2	2
01-28-17	Marcello pillars for burn plate, tall	0	2	2
01-28-18	Marcello rear stone	1	2	3
01-28-25	Marcello top plate for exit, front part	1	1	1
01-28-26	Marcello top plate for exit, rear part	1	1	1
01-80-30	Black door Marcello	1	1	1
	Part components in own box			
01-00-75	Product documentation	1	1	1
01-00-89	Sealing cord for burn plate, 160 cm	1	1	1
01-00-90	Installation instructions	1	1	1
01-00-91	Thin steel sheets / rods, 50 cm	4	4	4
01-00-95	Sealing cord for exit pipe, 50 cm	1	1	1
01-00-97	Reparation set	1	1	1
01-00-99	Steel rod	4	8	8
01-22-26	Thin steel sheets / rods, 20 cm	12	18	24
01-28-20	Steel ring Marcello, 15mm back	2	2	2
01-28-21	Steel ring Marcello, 15mm front	2	2	2
01-28-22	Steel ring Marcello, 30mm ring back part	2	3	4
01-28-23	Steel ring Marcello, 15/30mm	2	2	2
01-28-24	Steel ring Marcello, 30mm, front	0	1	2

Marcello 110 Exploded View

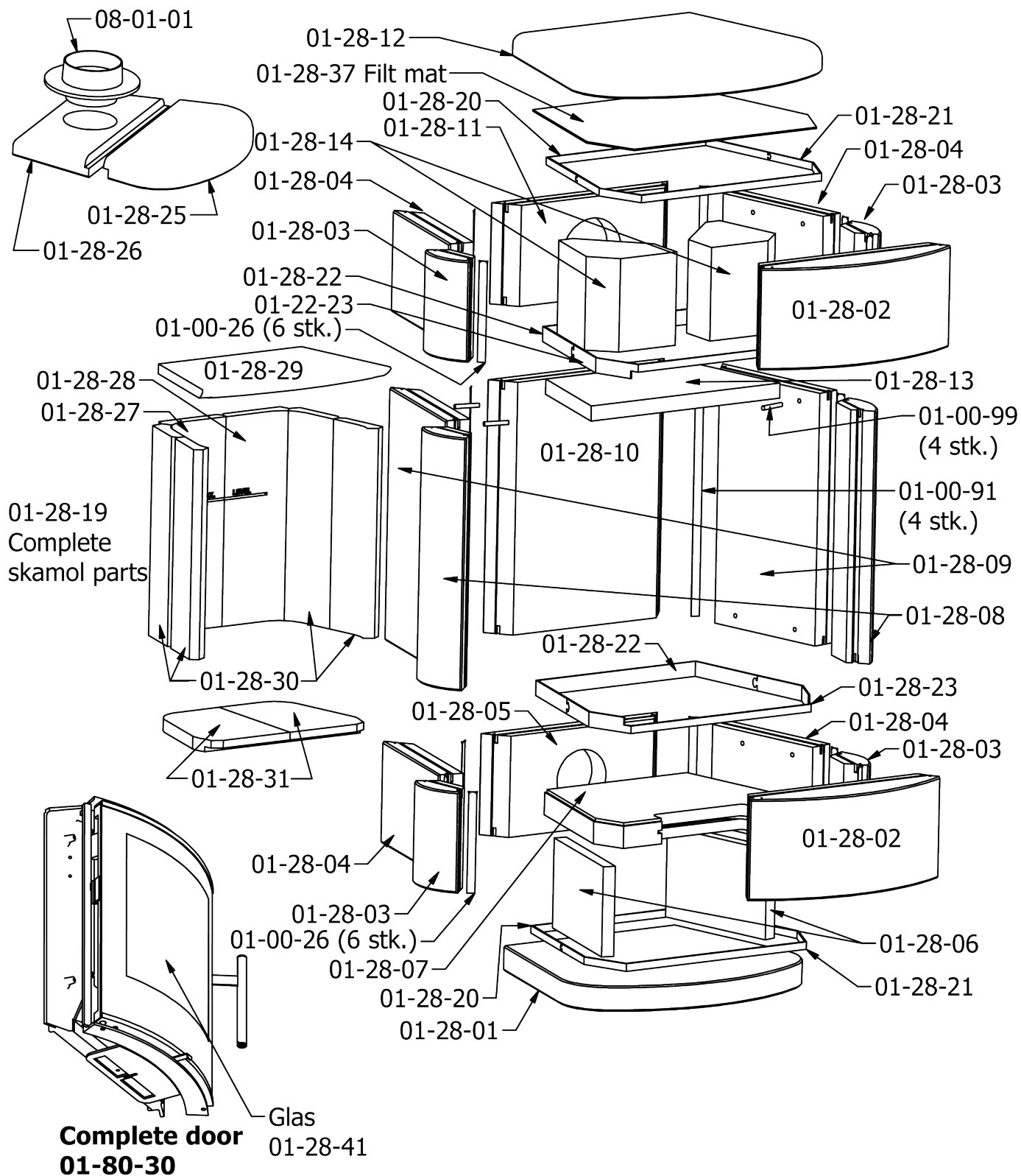

Marcello 140 Exploded View

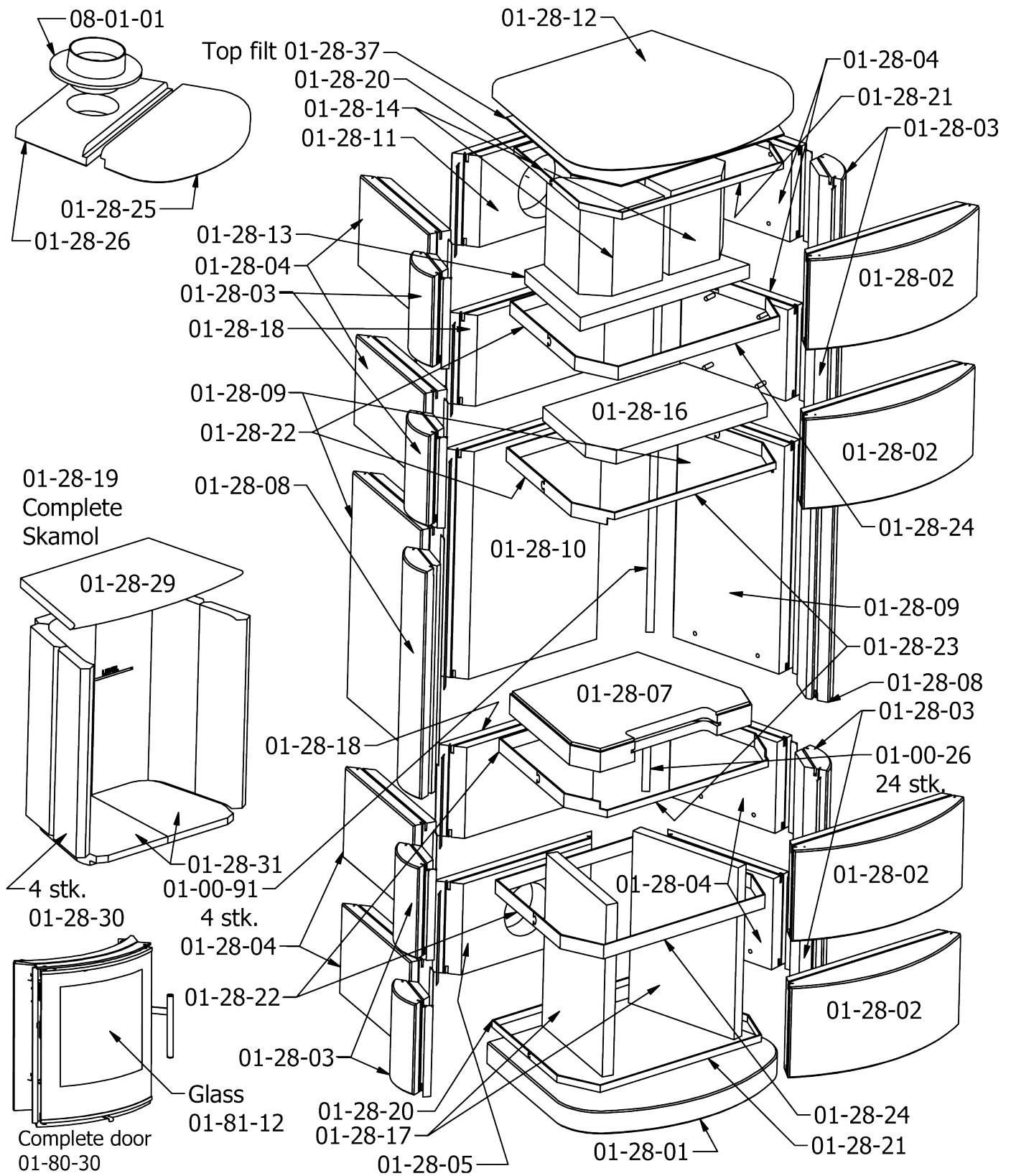

Model: Marcello

Assembly Manual

Before you begin:

- Please read and follow the assembly instructions carefully.
- Assembly should be done by two people as some of the components are very heavy.
- We recommend that you first sort the stones by size and shape.
- A repair kit is included for small repairs to the stones. Glue must not be used for assembly.

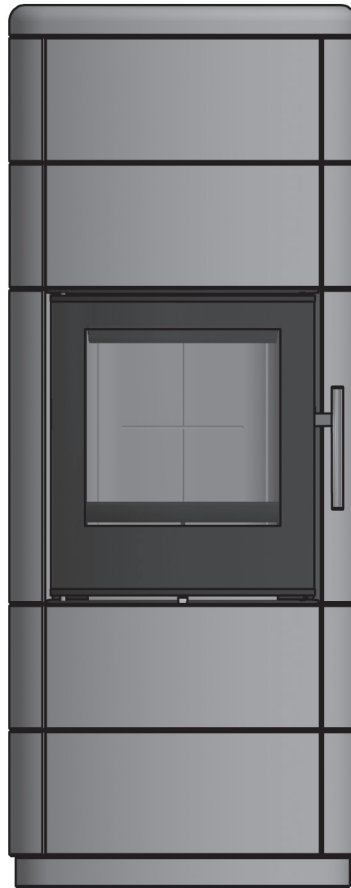

Suggested tools for assembly:

- Plastic or wooden mallet
- Multi-tip screwdriver
- Utility knife
- Work gloves
- Papertowel

Handle the stones carefully. Soapstone can be easily chipped or damaged if not handled correctly.

IMPORTANT 

- Before beginning assembling the stove, you must determine where the stove will be located.
- The stove must be located a safe distance from combustible materials including walls.

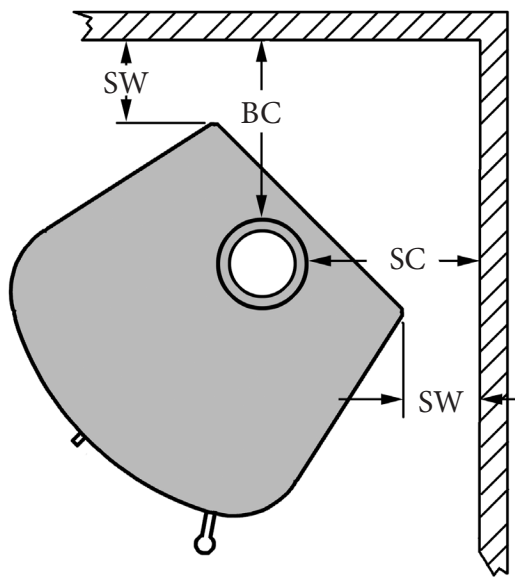
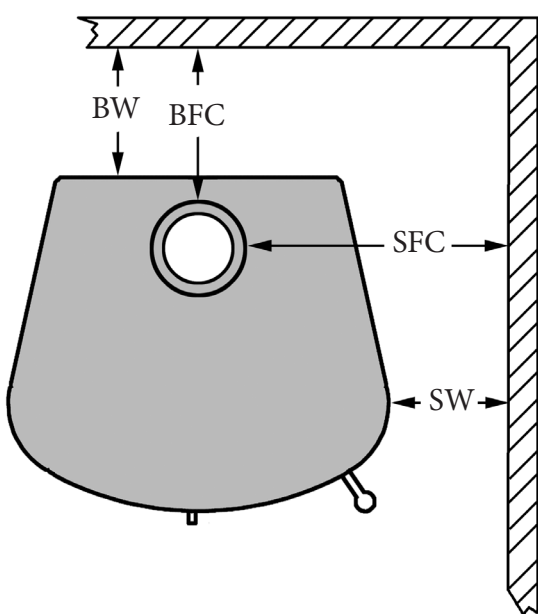

SW	Side Wall to Side	15 inch	381 mm
SFC	Side Wall to Flue Collar	23 inch	584 mm
BW	Back Wall to Unit	15 inch	381 mm
BFC	Back Wall Flue Collar	17 inch	432 mm

SWC	Side Wall to Corner	12 inch	305 mm
SFC	Side Wall to Flue Collar	19 inch	483 mm
BWC	Back Wall to Corner	12 inch	305 mm
BFC	Back Wall Flue Collar	19 inch	483 mm

DANGER 

Failure to locate the stove the minimum distances indicated, can result in a home fire and personal injury.

Floor Protection

Any floor that is not composed of concrete poured on earth requires protection from sparks and embers. The Babina is approved for installation using one of the following forms of hearth protection:

Any UL, ULC, or Warnock Hersey Listed Type 1 hearth board.
Any noncombustible material.

In the U.S. floor protection must extend continuously forward from the door opening at least 16 in. and 8 in. from the sides of the door opening. Protection must also extend 2 in. under the chimney connector. This will result in a minimum floor protector 38" wide x 37" deep. See Fig 3.

In Canada, floor protection must extend continuously 18" (460 mm) from the front of the stove and 8 in. (200 mm) from the sides and rear. It must also extend 2 in. (51 mm) to both sides under a horizontal chimney connector section. This results in a floor protector 38 in. x 45 in. (95 cm x 114 cm). See Fig. 3.

Fig 3. Floor protection dimensions

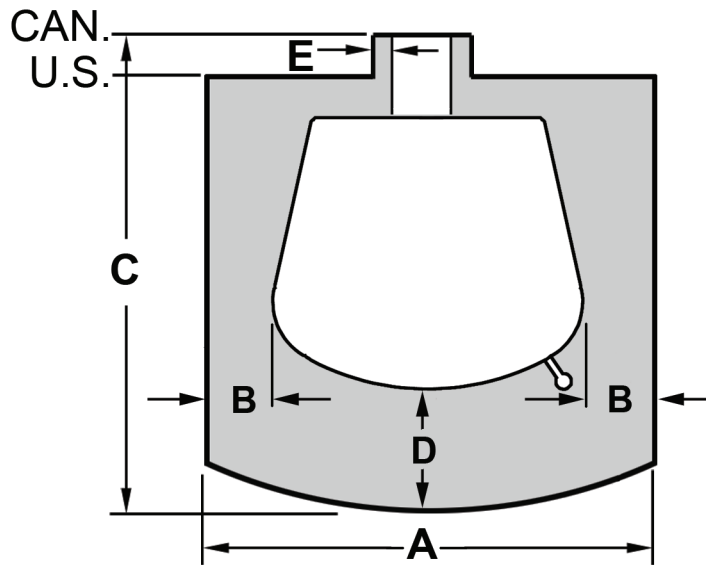

	A	B	C	D	E
U.S.	38 in.	8 in.	37 in.	16 in.	2 in.
	950 mm	200 mm	940 mm	400 mm	51 mm
CAN	38 in.	8 in.	45 in.	18 in.	2 in.
	950 mm	200 mm	1140 mm	460 mm	51 mm

WARNING

Failure to provide floor protection can result in a home fire and personal injury.

Exploded view

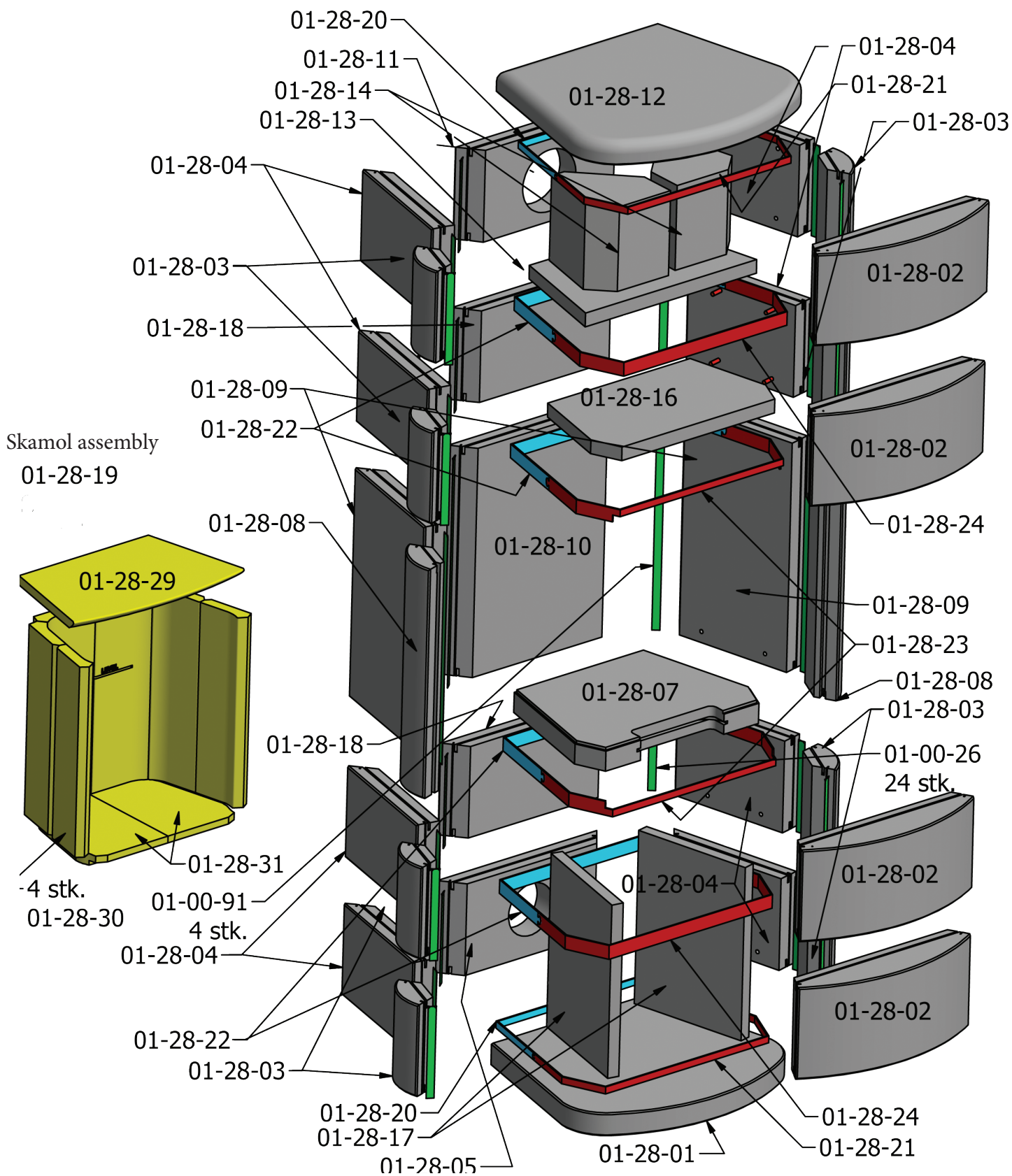

Step 1

1. Place the base plate on the floor/substrate of non-flammable material.
2. Check that the base plate is level, and adjust if necessary. (The base plate does not have felt glued on.)
3. Assemble the 15 mm 2-part steel ring, and center it on the base plate.
4. Put in place the rear wall with the air intake hole. If the stove is to be a closed system, connect a 4 in. fresh-air pipe. Use a sealing cord between the connection and the stone.
5. Put in place the side stones, front stone and corner stones.

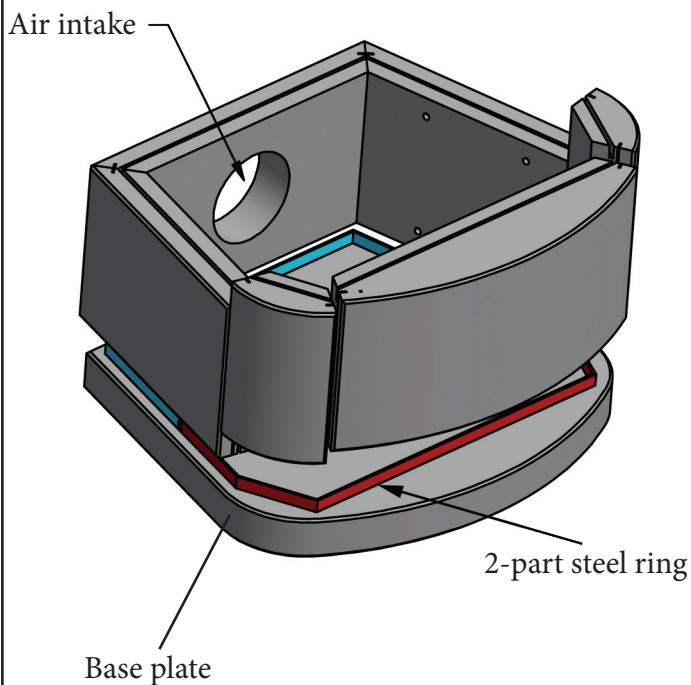

Step 2

If you are assembling a stove with two sections below the fire chamber, go to step 2a.

1. Put in place the 30 mm 2-part steel ring assembly with a recess for the door.
2. Insert (6) 200 mm metal sealing strips into the vertical tracks between the stones.
3. Place two supports for the fire plate next to the side stones and so that they are resting on base plate.
4. Place the fire plate down onto supports, with the countersinking for the sealing cord facing upwards.
5. Install fixed draft adjustment plate, into the recess on the bottom plate.

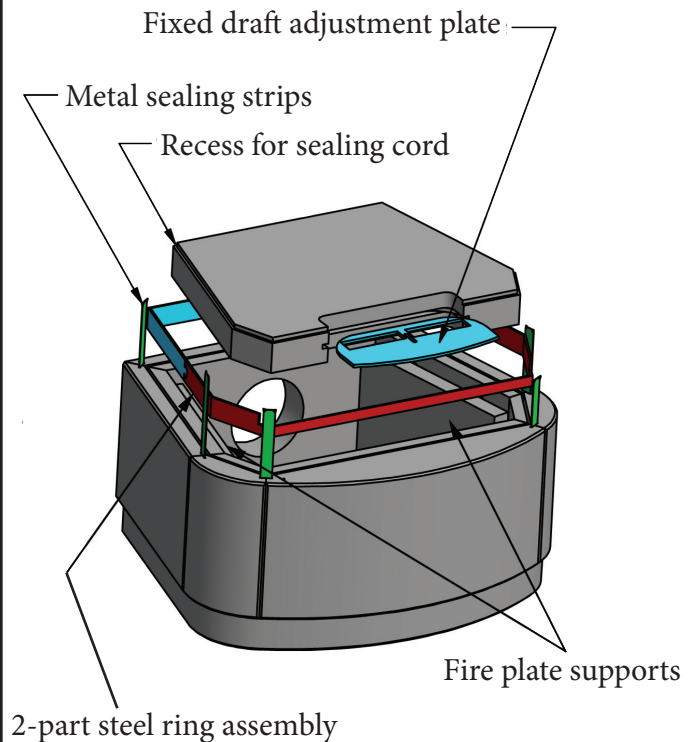

Step 2a For stoves with 2 sections below the fire chamber

1. Assemble 30 mm 2-part steel ring assembly and position it into the track as shown.
2. Insert the (6) 200 mm metal strips, into the vertical slots between the stones.

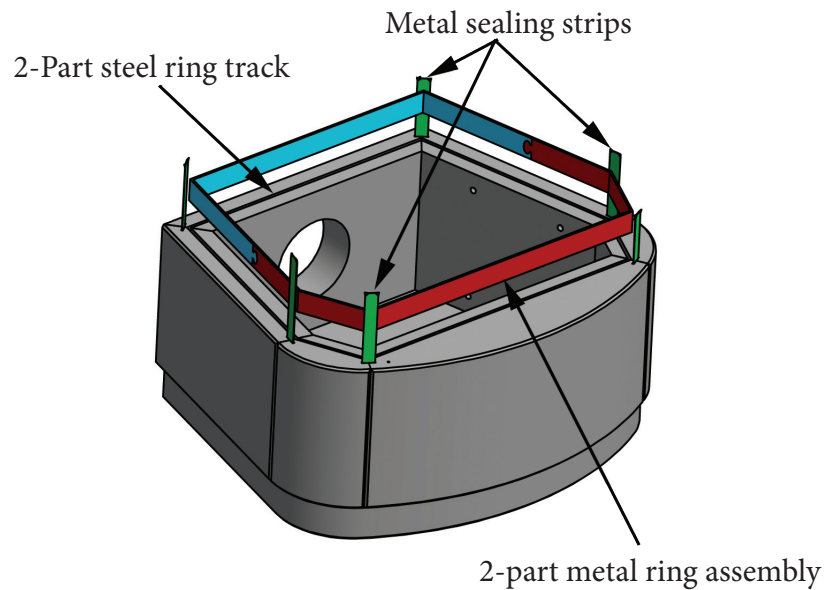

Step 2b

1. Put in place section 2 rear stone, 2 side stones, front stone and 2 corner stones.
2. Put in place the 2-part 30mm steel ring assembly with a recess for the door.
3. Insert (6) metal sealing strips into the vertical slots between the stones.
4. Place two support blocks for the fire plate next to the side stones and down onto the base plate.
5. Place the fire plate down onto supports, with the countersinking for the sealing cord facing upwards.
6. Slide into place the fixed draft adjustment plate, into the recess on the bottom plate.

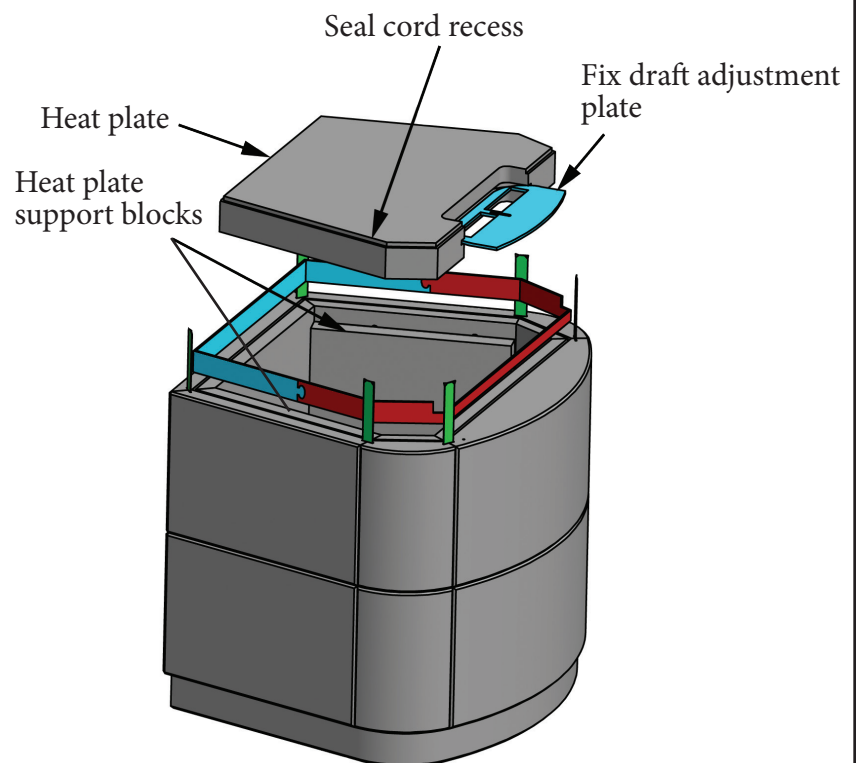

Step 3

1. Place the door on the front stone.
2. Put in place two corner stones next to the door frame assembly.

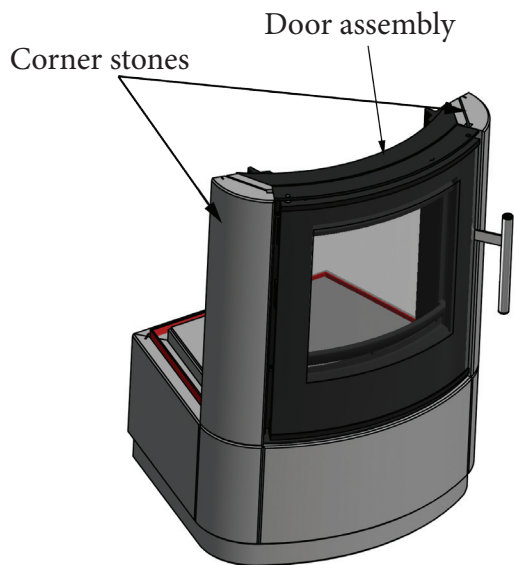

Step 4

1. Put in place the rear stone.
2. Put in place the two side stones.
3. Slide in place the 30 mm 2-part steel ring assembly with recess for the door.
4. Insert the (4) 246 mm metal sealing strips into the vertical slots between the stones.

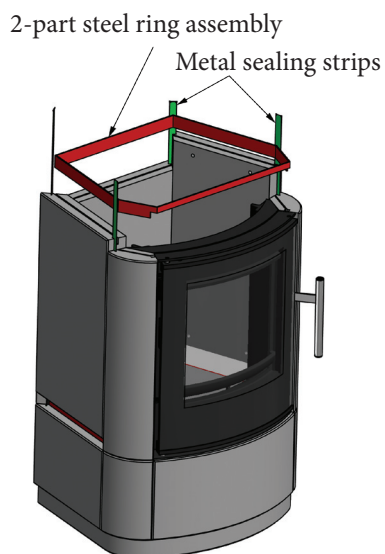

Step 5 Sealing cord

1. Tuck the sealing cord down into the track around the fire plate.

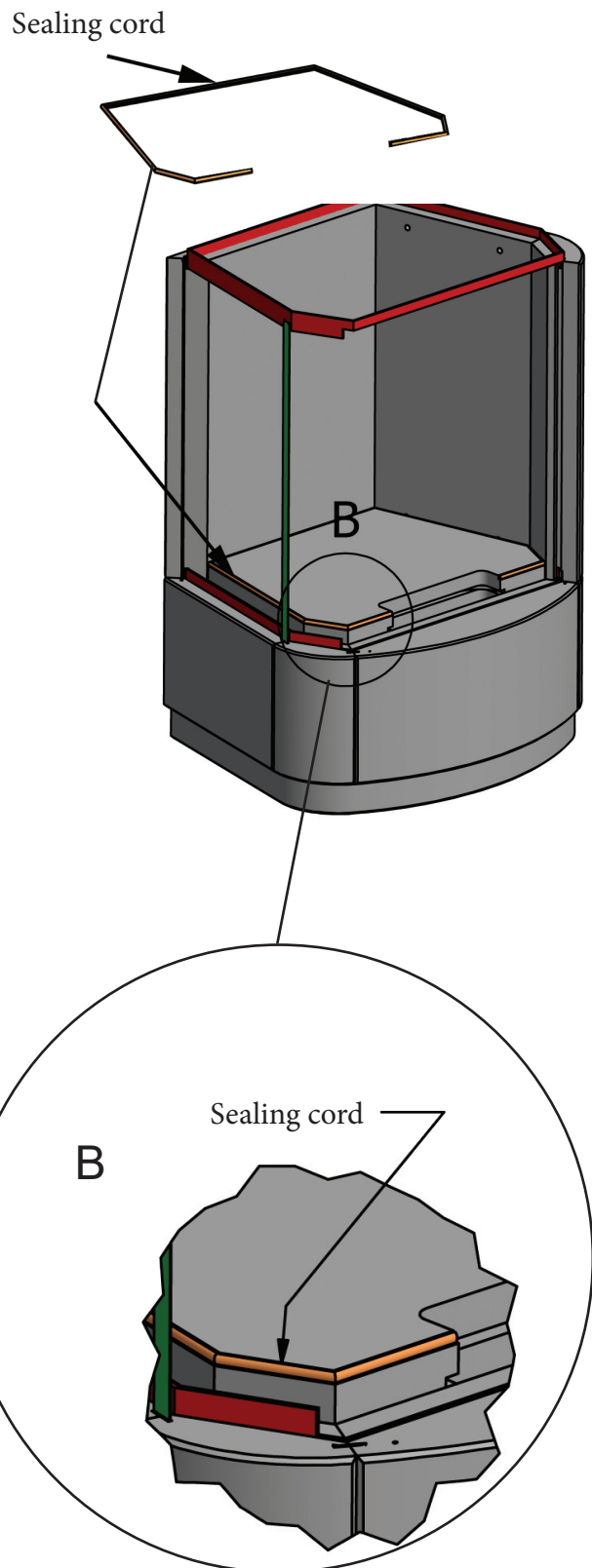

Step 6 Draft adjustment

1. Disassemble the cover for the draft adjustment. (Use the enclosed 3 mm Allen key)
2. Put in place the movable draft adjustment plate with the draft adjustment handle.
3. Fit the cover in front of the draft adjustment.

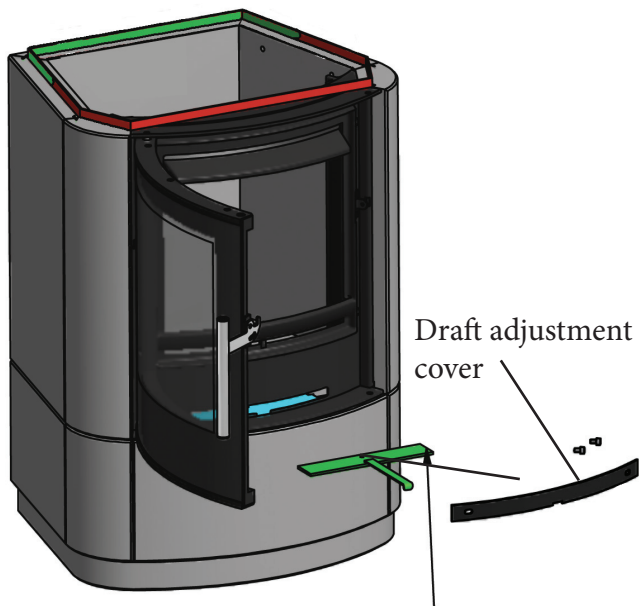

Movable draft adjustment plate

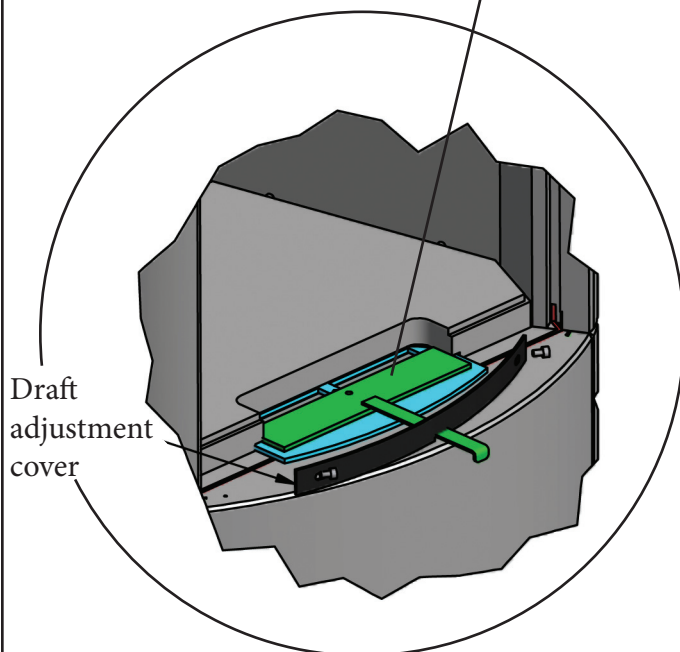

Step 7

Sealing joints and seams with silicone fire sealant

For best stove performance, we recommend that all the interior joints, except the Skamol assembly, be sealed with the Silicone Fire Sealant that is included with the stove.

- Begin by sealing the vertical and horizontal seams for the burn chamber.

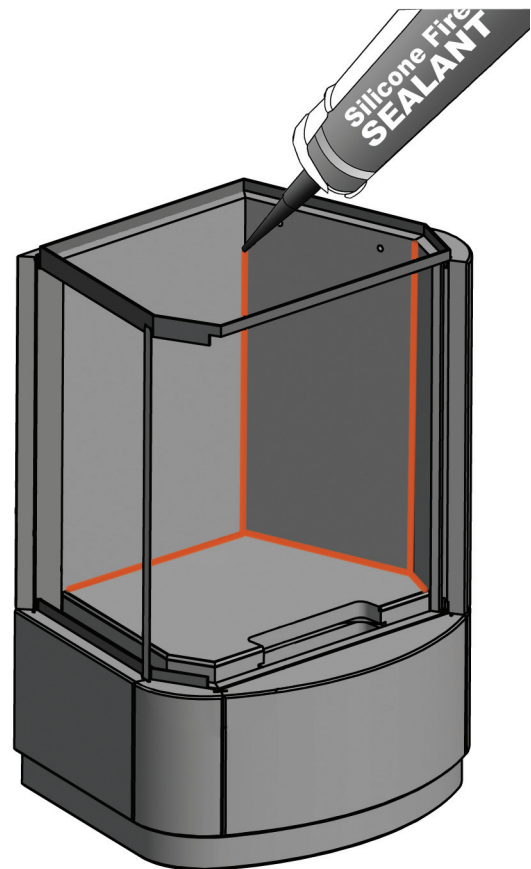

Only the burn chamber and the sections above it should be sealed.

Step 8 Sealing the joints

After applying the silicone sealant to joints and seams, smooth it out with your finger (a protective glove is provided with the silicone sealant so that you don't get sealant on your bare hands).

Do Not apply sealant to the stove's exterior joints or seams.

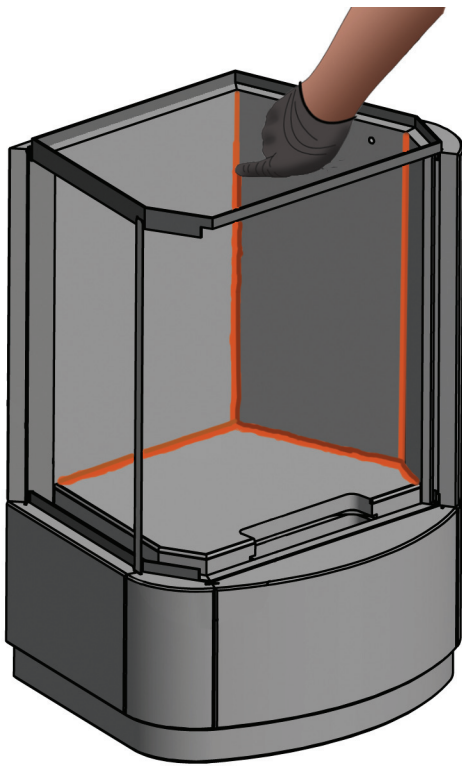

After you have completed sealing the burn chamber section, assemble the next section above it and then seal that section following the same procedure. There after, follow the same procedure for each section above the burn chamber.

Step 9 Skamol assembly

1. Put in place the Skamol liners. The two rear ones contain level marks and text for max height for laying in firewood.
2. Place the side Skamol liners **A** next to the door frame.
3. Slide the Skamol liners **B** down between the rear liner and liner **A**.

Level marks and text for max height

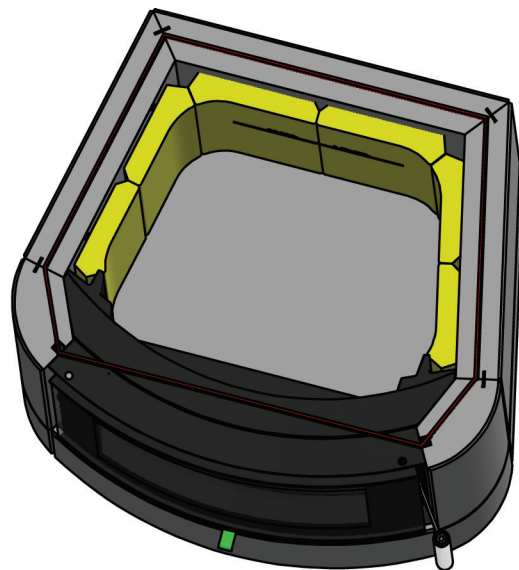
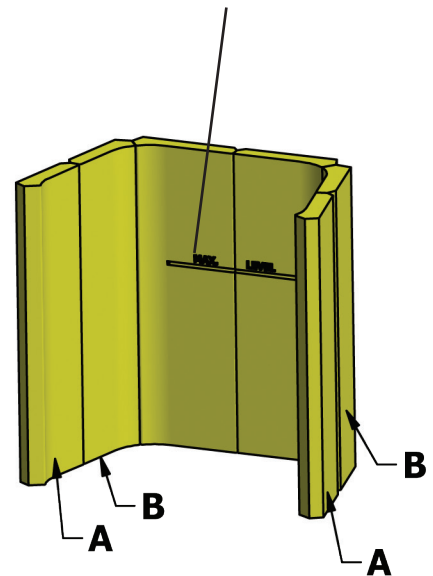

Step 10 Skamol assembly

1. Place the two-part Skamol bottom down onto the soap stone plate in the bottom, with the recess for the door facing down.
2. Put in place the Skamol ceiling down onto the vertical lining plates, with the recess for the vertical plates facing down.

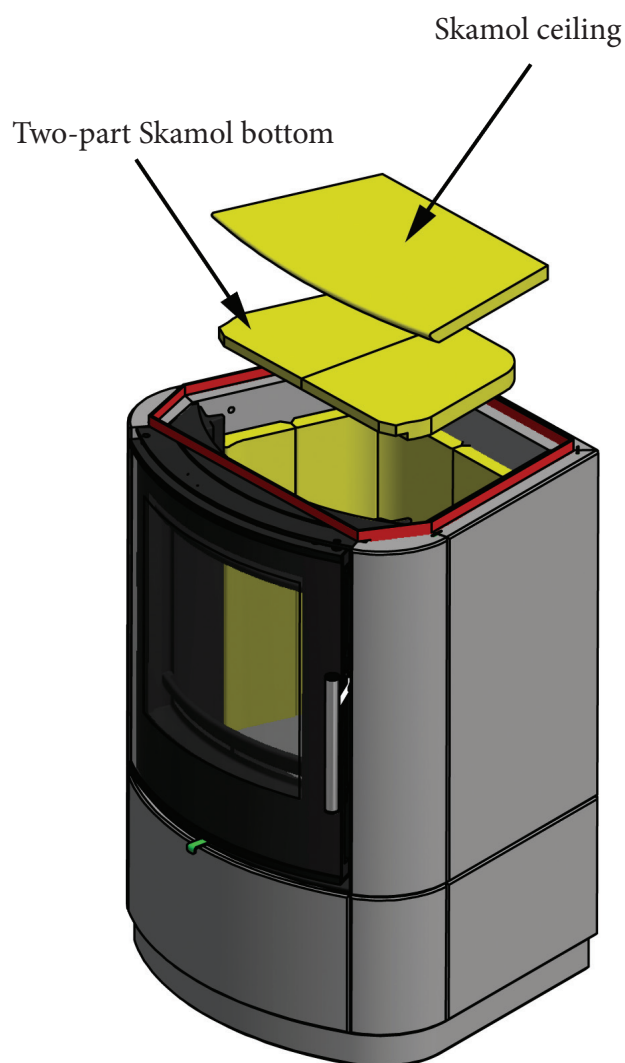

Step 11 Skamol assembly

1. Insert (4) 8 mm steel dowels into the side stones.
2. Place the soapstone plate so that it is resting on the steel dowels and next to the rear wall.

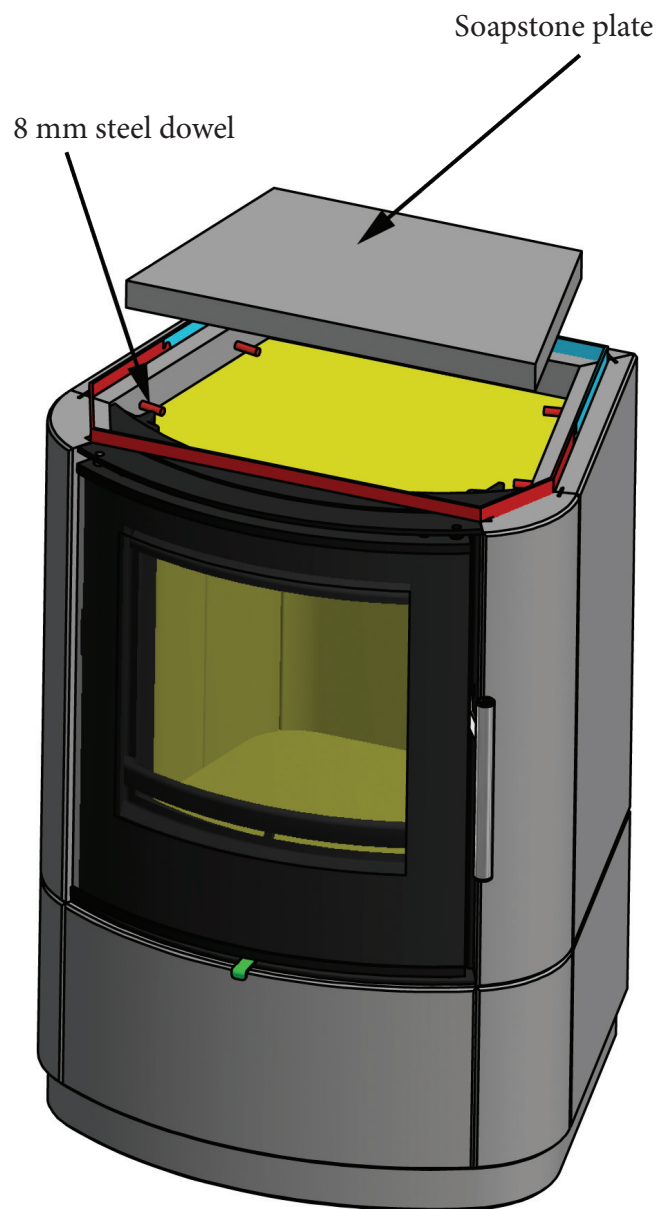

Step 12

1. Place the rear stone in position as shown.
2. Assemble the side stones and the front stone.
3. Put in place the forward corner stones.
4. Slide into place the 15 mm two-part steel ring assembly.
5. Insert (6) 20 cm metal sealing strips into the slots between the stones.

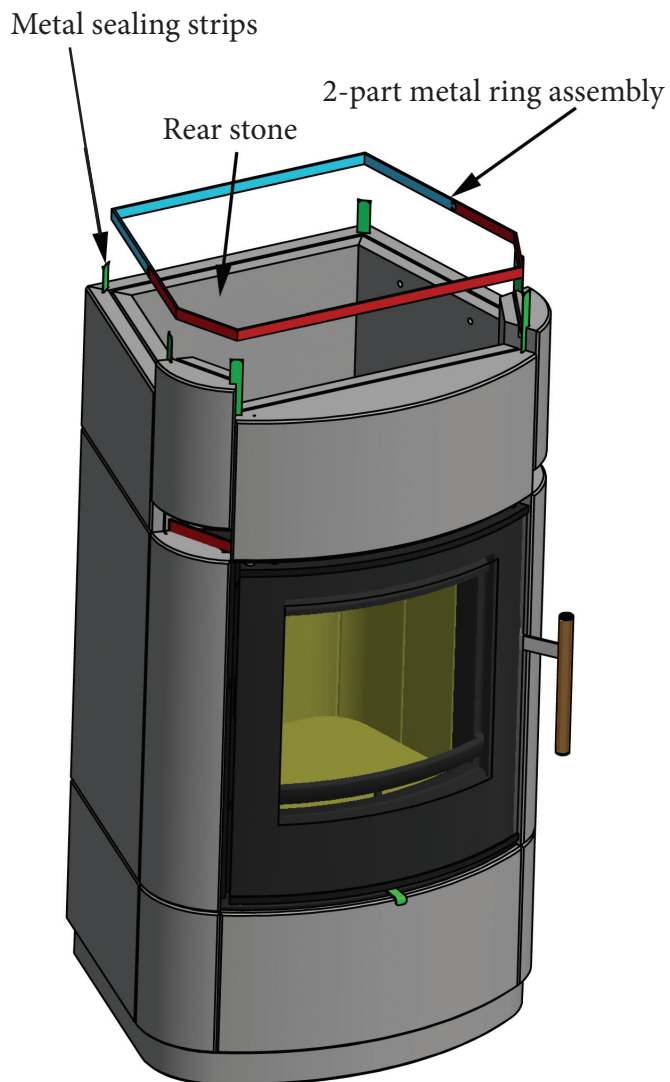

Step 13

1. Put in place the rear stones, 2 side stones, front stones and 2 corner stones.
2. Place the 30 mm two-part steel ring assembly into the track provided.
3. Insert the (6) metal sealing strips into the vertical slots between the stones.
4. Insert the (4) 8 mm steel dowels into the bottom holes of the side stones.
5. Apply apply fire sealant (see step 7 & 8)

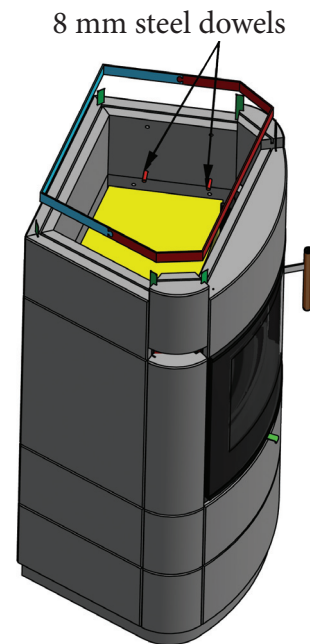

Step 14

1. Put in place the smoke direction plate with the opening at the rear.

Smoke direction plate

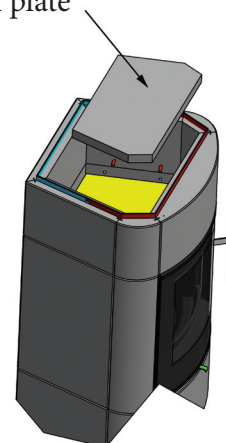

Step 15

1. Put in place the smoke hood stone.
2. Assemble the side stones and the front stone.
3. Put in place the corner stones.
4. Place the 15 mm 2-part steel ring assembly.
5. Insert (6) metal sealing strips into the slots between stones.
6. Apply fire sealant (see steps 7 & 8)
7. Insert (4) 8 mm steel dowels into the side stones as shown below.
8. Place the smoke direction plate so that it rests on the steel dowels, and position it against the rear wall.

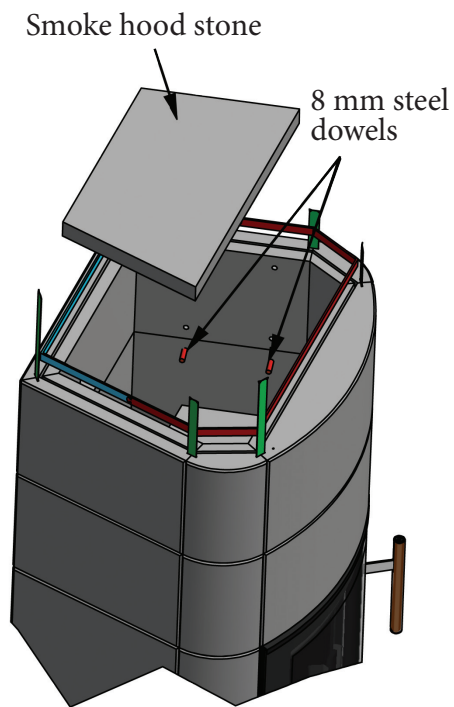

Step 16

1. Place the labyrinth blocks as shown below.

Labyrinth blocks

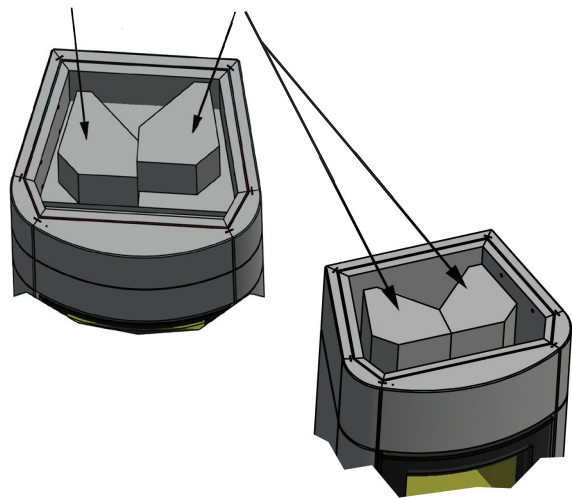

Step 17

1. Place the (rear) part of the top plate as shown.
2. Place the (front) part of the top plate as shown.
3. Insert the flu adapter. Use the sealing rope between the flu adapter and the rear top plate.

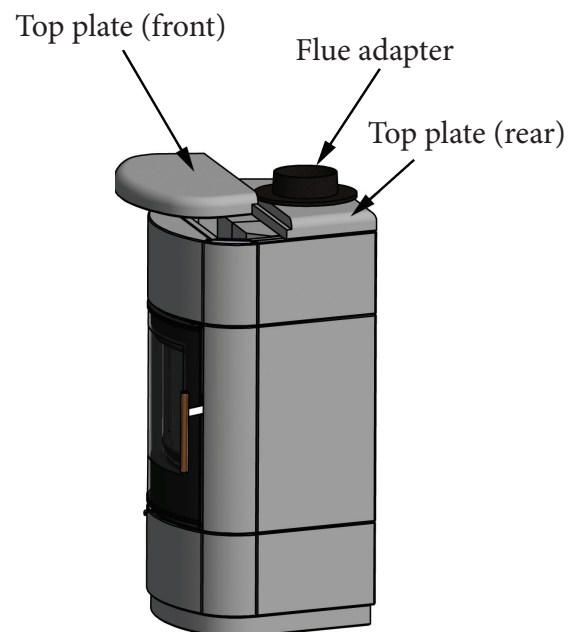

How to use your Norsk Kleber Soapstone Stove

CAUTION: 

Do not use this stove in a manner that is not consistent with these instructions. Failure to do so can result in harm to people and property.

Ventilation of the room

The stove needs air (oxygen) to achieve good combustion. The air is supplied from the room where the stove is, or connected in a closed system. The air enters through the 4.5 inch hole in at the back of the stove. In case of insufficient ventilation, combustion becomes incomplete, so that toxic gases can enter the room.

Extra ventilation is required if the stove is in a well-insulated room, or in rooms with mechanical ventilation, eg. central exhaust system or extractor fan in an open kitchen. Additional ventilation is achieved by installing a ventilation grill in the outer wall. Make sure that other equipment that uses air (for example: kitchen fan or bathroom fan) has its own connection to fresh air or is switched off when firing with the stove. The stove can also be connected to fresh air supply in a closed system. When using such a set, extra ventilation is not required.

Supply of combustion air

The combustion air for the combustion chamber can be supplied directly or indirectly to the stove. In most cases the stove works great with indirect supply from wall valves in the outer wall. In newer more airtight houses, it may be necessary to supply the combustion air directly into the combustion chamber.

If the combustion air is to be supplied as described above, this must be prepared before the stove is mounted to the chimney. The supply air duct must be insulated so that condensation does not occur.

The air supply pipe has a diameter of 4 inches. If a straight pipe is used it can have a maximum length of 39 feet. If there are bends in the pipe, count each bend as 3 feet and subtract the total from 39 feet.

Floors and walls

- The floor on which the stove is mounted must have sufficient carrying capacity. Most standard floors can withstand stoves up to 950 lb. If you are in doubt, please contact a specialist.
- Provide sufficient distance between the stove and combustible material such as wooden walls and furniture. See the Safety Label for recommended distances.
- The connection pipe to the chimney also radiates heat. The minimum distance requirement from an un-insulated flue pipe to combustible material, is 12 inches.
- A blanket must be at least 32 inches from the fire.

Fuel

Use only natural cut and split wood that is sufficiently dried. Do not use other fuels as this may cause serious damage to the stove. It may also pollute the environment and/or cause a soot fire.

DO NOT USE :

- Treated wood
- Reclaimed lumber
- Impregnated wood
- Plywood
- Lacquer
- Chipboard
- Plastic
- Waste paper
- Household waste

A little more about wood

Use dry wood with moisture content of less than 17%. This means that the wood has dried for about 1-2 years.

Wood should be cut in 10 to 12 inch lengths.

Do not use unseasoned wood. Raw wood gives little heat because much of the energy is used to evaporate the water. It gives a lot of smoke and soot coating on the internal surfaces of the stove and in the chimney. The water vapor that condenses in the stove can leak out between the stones, causing black spots on the stone and floor. If the soapstone gets such soot stains, they can be removed with the help of soap and cloth, or possibly fine sandpaper (180). The water vapor can also condense in the chimney to form creosote. Creosote is highly flammable and can cause soot fire.

Firing

Your masonry heater does not need to be, and should not be, fired constantly to provide an even heat. Firing with several hours intervals is optimal for these type of stoves. Because of the heat retaining characteristics you will experience an even heat output when firing 3-4 times a day. We recommend using about 4 lbs (2 kg) of wood for one firing, and never more than 6 lbs (3 kg). In this way your stove will provide a heat output during the whole day and night of about 1-3 kW when firing 3 or 4 times a day. If you need more or less heat you can shorten or lengthen your firing intervals.

Make sure you have a good draft in your chimney. In the beginning of the firing cycle you should have full draft. This can be reduced a bit after the first five minutes. Never close the draft during the firing, since this will lead to a very inefficient combustion and release of particles in the air. After the fire has been extinguished, close the draft completely to make sure you do not vent the stove from the inside, losing the accumulated heat through the chimney. Your stove, depending on the size and how hard it has been fired, will keep you warm for 6 to 12 hours.

You should only fire with dry firewood with maximum moisture content of 20%, this is a prerequisite for the well functioning of your stove. Make sure your firewood is also cut in sufficiently small pieces. We recommend pieces of not more than one lb. each. The best results will be when firing from the top, with small pieces of wood lying on top of the wood-stack as the picture below shows.

Example of a wood stack and how to light it.



For further information see also our homepage www.norskkleber.com

The adjustment of the air into the burn chamber is done with the lever at the bottom of the door. When the lever is completely out you have maximum air supply. As long as you have fire the lever should never be less than half-way out to avoid incomplete burning of the wood.

Starting and maintaining a fire:

1. With primary air control lever in the full open position, place two short 1/4-split logs on the firebox floor, perpendicular to the rear wall, about 6 inches apart.
2. Place kindling across the base logs.
3. Place one or two smaller logs on top of the kindling.
4. Place newspaper between the two bottom logs under the kindling. Light the newspaper and close the door. Continue to add kindling and small logs as necessary to build the fire. Keep the air control fully open until the fire is well-established.

BURN ONLY SOLID WOOD DIRECTLY ON THE BOTTOM PLATE OF THE STOVE. DO NOT ELEVATE THE FIRE IN ANY WAY. DO NOT USE ANY STOVE GRATES.

WARNING 

ALWAYS WEAR STOVE GLOVES WHILE TENDING THE FIRE.

NEVER ALLOW THE FIRE TO REST DIRECTLY ON THE GLASS. KEEP THE LOGS SPACED AT LEAST ONE INCH FROM THE GLASS TO ALLOW FOR PROPER AIR FLOW WITHIN THE STOVE. AVOID STRIKING THE GLASS WITH LOGS.

OPERATE THIS STOVE ONLY WITH THE FRONT DOOR AND ASH DOOR FULLY CLOSED. OPERATION WITH THE DOOR PARTIALLY OPEN MAY RESULT IN OVER-FIRING. IF THE DOOR IS LEFT PARTIALLY OPEN, GAS AND FLAME MAY BE DRAWN OUT OF THE STOVE CREATING SAFETY RISKS FROM BOTH FIRE AND SMOKE.

The Babina+ is designed to burn natural wood only. Higher efficiencies and lower emissions generally result when burning air-dried, seasoned hardwoods, as opposed to softwoods, green or freshly cut hardwoods. Wood that has been air-dried for a period of 6 to 14 months will provide the cleanest, most efficient heat. Wood seasoned more than 2 years will burn too quickly to take advantage of the stove's low-end efficiency strength.

A seasoned log will have check marks on the ends and be lighter than an unseasoned log which will show little or no check marks.

We recommend using a moisture meter to determine the moisture content of your wood. For purposes of home heating, your fuel should have a moisture content between 12 - 20%. Wood with higher moisture content will burn, however, very inefficiently. Most of its heat value will be lost to driving water out of the wood. Worse, that moisture will condense as creosote in the relatively cool chimney flue, increasing the potential for a chimney fire. Use of unseasoned wood defeats the purpose of any modern wood-burning stove.

Air control settings

A single lever regulates the primary air flow that controls the intensity of the fire and consequent heat output and burn time. The lever is located within the slot below the stove door.

Primary air enters the stove above the door and washes over the glass before reaching the fuel. Some air is also provided to the fuel at the bottom of the door through a small hole. This provision of air is also called *pilot air*. It is used to keep the fire going, preventing it from extinguishing when the air wash is regulated down to a minimum.

Unrestricted secondary air is delivered through manifolds at the rear and top baffle where it ignites volatile gases that would otherwise pass unburned into the environment. In this way, the wood is burned efficiently and exhaust is minimized. When the fire is burning well, little or no smoke will be evident from the chimney.

When first starting or reviving the fire, the control lever should be pulled out completely to allow the maximum amount of air into the stove. After the fire is well-established, the lever should be set at position to moderate incoming air, but never less than half its maximum, to maintain the desired long term burn time. However, always keep enough air to allow the fire to burn. A genuine soapstone stove does not need to be burned at a low burn rate to have heat for a longer time: most of the heat is stored in the stones and will be radiated out after the fire has extinguished.

In general, the more air made available to the fuel will result in the hottest fire intensity and the fastest fuel consumption. Do not smolder the fire in your genuine soapstone stove!

Adding firewood to a still hot soapstone stove

When reloading the stove while a bed of hot embers still exists, follow this reloading procedure:

- Never open the door when there is still fire (flames) in the burn chamber. The load has to burn out completely first.
- Always use the stove mitt when tending to the fire.

- Before you open the door, place the Air Control Lever in the full open position.
- Always wait a few seconds before opening the door. This allows the renewed air circulation to clear unburned gases from the firebox. Hold the door open just slightly for a couple of seconds before opening it fully. This will also help ensure that no smoke escapes into the room.
- Use a stove tool or poker to distribute the hot embers equally around the firebox and push ashes into the ash pan.
- Load the fuel, usually with smaller logs first.
- Close the door and secure the latch, the wood will start to burn after a few minutes.

Emptying ashes

Having some of the ashes always in the stove is beneficial for the firing. The ashes isolate to the cold bottom, leading quicker to high temperatures in the burn chamber, and give some space for air to get under and at the sides of the wood, thus improving the combustion.

After a number of firings it will be necessary to remove part of the ashes. Opening the door and simply using a suitable tool to dig out ashes can do this. This should not be done before the stove is completely cooled down! Wait at least 12 hours after the last firing before doing so. The ashes should be put in a bucket of incombustible material, such as an iron bucket.

After firing with wood, a relatively small amount of ash occurs. This ash bed is a good insulator and provides better combustion. Therefore, leave a thin ash layer on the bottom of the oven.

Regularly remove the excess ash.

Use an ash spade and fill the ash in a suitable ashtray which is then emptied at a fire-proof location, it is recommended that ash discharge be done at least 12 hours after firing is finished.

Only use a container of noncombustible material, like iron, to put the ashes into. Put a lock on the container until all ashes, coals and cinders, are thoroughly cooled.

Exterior cleaning

The stone can be washed easily with ordinary household detergent. Stains of soot and soot water are removed by brushing lightly with fine sandpaper (180).

Creosote Formation and the Need for Removal

When wood is burned slowly, it produces tar and other vapors that combine with moisture to form creosote. Creosote vapors condense in the relatively cool chimney flue, and creosote residue accumulates on the flue lining. When ignited, this creosote fuels an extremely hot fire.

The chimney connector and chimney flue should be inspected at least every two months during the heating season to determine if creosote buildup has occurred.

If creosote has accumulated, it should be removed to reduce the chance of a chimney fire. A qualified chimney sweep or other authorized service person can provide this service.

It is also important to remember that chimney size, temperature and height all affect draft which in turn affects the formation of creosote. An exterior chimney, whether masonry or prefabricated steel, will be exposed to cold outside temperatures, and consequently, will be more prone to creosote accumulation than an interior flue.

Creosote may also form inside the stove, at the top in the highest section. This happens since the flue gas temperature can be quite low, leading to condensation and the formation of some creosote on the inside of the stove at the stone surfaces. Creosote has an insulating effect, so it's important that the stove interior be cleaned annually.

Cleaning the stove interior

Caution: Make sure the stove is cold.

1. Locate necessary equipment such as: good lighting (head lamp), steel scraper / ice scraper, ashtray or ash vacuum and preferably a pair of gloves.
2. Cover the floor and furniture around the stove. For items 3 and 4 below, it is an advantage and to have two people, since the top plate is heavy.
3. Tilt the top plate and scrape/vacuum away the soot on the underside of the top plate. (Two-piece top plate, for top-mounted chimney, the rear plate should not be removed for cleaning).
4. Lift off the top plate.
5. Scrape off soot on smoke conductor plates and pick out the parts. The ash is swept down the stove or sucked away eventually.
6. Pick out steel studs on which horizontal smoke conductor plates lie and scrape away the soot from the stones.
7. The ash is now in the bottom of the stove, and is removed with ash vacuum, or ash spade/bucket.
8. Inspect Skamol plates in combustion chamber and replace if defective.
9. Lift the cover over the draft control and inspect the draft control. If needed, lubricate the shaft and guide pin with copper grease.
10. Replace the steel dowel pins, the smoke guide plates, and put the top plate back in place.

When firing with dry wood and with good draft (full opening for combustion air while firing) there should be very little creosote formation, however we advise that you inspect for creosote formation inside the stove at the same time when inspecting the chimney.

Cleaning the glass

1. Remove dust and loose-fitting soot with a dry cloth.
2. Wet a newspaper or paper towel with water, dip the wet paper in the box and wipe the soot on the glass. Then wipe with a dry clean cloth or paper.
3. Clean the glass again with glass cleaner.

Do not use abrasive or corrosive products to clean the glass. If the stove's glass is crushed or cracked, the glass must be replaced before the stove is used again.

Replacing the glass

Always operate the door slowly and cautiously to avoid cracking or breaking the glass. Never use the door to push wood into the firebox. If the glass becomes cracked or broken follow the following replacement procedure:

1. First loosen and then carefully remove the four glass clips from the inside of the door. Remove all pieces of the glass panel and gaskets.
2. Remove all remaining debris from the glass area using a wire brush.
3. Apply a small bead of gasket/stove cement and the new gasket. Do not overlap the ends of the gasket rope.
4. Center the new glass panel over the gasket and loosely reinstall the glass clips. Tighten the clips, alternating at opposite corners. Avoid applying uneven pressure on the glass.
5. It may be necessary to retighten the glass clips after the stove has been used again and the gaskets has seated.

Warranty

Norsk Kleber and its U.S. importer, Hestia Industries, warrant this soapstone stove to be defect-free in material and workmanship to the original purchaser from the date of purchase as follows:

Check with your dealer in advance for any costs to you when arranging a warranty call.

Mileage or service charges are not covered by this warranty. This charge can vary from store to store.

Year 1 - COVERAGE: PARTS & LABOR

Norsk Kleber or its authorized agent will provide repairs deemed necessary to restore your stove to normal operation free of charge provided the stove was operated as directed in the Owner's Manual. See Conditions and Exclusions for any circumstances where your stove would not be covered by the Norsk Kleber warranty.

Years 2- 5 COVERAGE: PARTS

Norsk Kleber or its authorized agent will provide parts deemed necessary to restore your stove to normal operation at no charge. You will be responsible for all cost of labor associated with the repair and replacement of defective parts. See Conditions and Exclusions for any circumstances where your stove would not be covered by the Norsk Kleber warranty.

Years 5 -10 COVERAGE: SOAPSTONE(S)

Norsk Kleber or its authorized agent will provide replacement soapstone(s) at no charge when deemed they are defective by Norsk Kleber or its authorized agent. See Conditions and Exclusions for any circumstances where your stove would not be covered by the Norsk Kleber warranty.

CONDITIONS & EXCLUSIONS

1. This soapstone stove must be installed by a qualified installer. It must be installed, operated, and maintained at all times in accordance with the instructions in the Owner's Manual. Any alteration, willful abuse, accident, neglect, or misuse of the product shall nullify this warranty.
2. This warranty is nontransferable, and is made

to the ORIGINAL purchaser, provided that the purchase was made through an authorized Norsk Kleber dealer.

3. Discoloration and some minor expansion, contraction, or movement of certain parts and resulting noise, is normal and not a defect and, therefore, not covered under warranty.
4. This warranty does not cover misuse of the stove. Misuse includes over-firing of this appliance and can cause serious damage and will nullify this warranty. Misuse includes use of salt-saturated wood, chemically treated wood, or any fuel not recommended in the manual.
5. The warranty, as outlined within this document, does not apply to the chimney components or other non-Norsk Kleber accessories used in conjunction with the installation of this product. If in doubt as to the extent of this warranty, contact your authorized Norsk Kleber retailer before installation.
6. Damage to the fire chamber due to mishandling, removal, cleaning, or other handling is not covered. Degradation of the fire chamber due to burning of anything other than natural cord wood is not covered. Burning of trash, garbage, artificial or paper logs, gift wrappings, coal, lighter fluids, chemical starters, treated or painted wood, driftwood or chemical cleaners will void the fire chamber warranty.

Exclusions

1. Exclusions to this Warranty include: injury, loss of use, damage, failure to function due to accident, negligence, misuse, improper installation, alteration or adjustment of the manufacturer's settings of components, lack of proper and regular maintenance, damage incurred while the appliance is in transit, alteration, or act of God.
2. This 5 Year warranty excludes damage caused by normal wear and tear, such as stone discoloration or chipping, worn or torn gaskets. Also excluded is damage to the appliance caused by abuse, improper installation, modification of the appliance, or the use of fuel other than that for which the appliance is configured (use cord wood only).
3. Norsk Kleber and its U.S. importer Hestia Industries is free of liability for any damages caused by the appliance, as well as inconvenience expenses and materials. Incidental or consequential damages are not covered by this warranty. In some states, the exclusion of incidental or consequential damage may not apply.
4. This warranty does not cover any loss or damage incurred by the use or removal of any component or apparatus to or from the Norsk Kleber without the express written permission of Norsk Kleber or its U.S. importer, Hestia Industries. This warranty does not cover a stove repaired by someone other than a Norsk Kleber authorized dealer and is not part of this 5 year warranty.
5. This warranty is automatically voided if the appliance's serial number has been removed or altered in any way. If the appliance is used for commercial purposes, it is excluded from this warranty.
6. No dealer, distributor, or similar person has the authority to represent or warrant Norsk Kleber products beyond the terms contained within this warranty. Norsk Kleber assumes no liability for such warranties or representations.
7. If for any reason any section of this warranty is declared invalid, the balance of the warranty remains in effect and all other clauses shall remain in effect.
8. This 5 year warranty is the only warranty supplied by Norsk Kleber., the manufacturer of the appliance. All other warranties, whether express or implied, are hereby expressly disclaimed and purchaser's recourse is expressly limited to the warranties set forth herein.

IF WARRANTY SERVICE IS NEEDED:

1. If you discover a problem that you believe is covered by this warranty, you **MUST REPORT** it to your Norsk Kleber dealer **WITHIN 30 DAYS**, giving them proof of purchase, the purchase date, and the model name and serial number.
2. Norsk Kleber has the option of either repairing or replacing the defective component.
3. If your dealer is unable to repair your soapstone stove defect, he may process a warranty claim through Norsk Kleber, including the name of the dealership where you purchased the appliance, a copy of your receipt showing the date of the stoves purchase, and the serial number on your stove.
4. Check with your dealer in advance for any costs to you when arranging a warranty call. Mileage or service charges are not covered by this warranty. This charge can vary from store to store.
5. Any appliance or part thereof that is repaired or replaced during the limited warranty period will be warranted under the terms of the limited warranty for a period not to exceed the remaining term of the original limited warranty or three (3) months, whichever is longer.